



Davis ®

PRECISION WEATHER INSTRUMENTS

CATALOG | GLOBAL

Over 35 Years of Weather Innovation

1980

1984 | TURBO METER

This hand-held device reads wind speed in miles/hour, knots, feet/minute, or meters/second.



1988 | DIGITAR WEATHER PRO

A micro weather station for measuring basic weather conditions. The Weather Pro is the origin of Davis's home and industrial weather market leadership.



1989 | DIGITAR WEATHER MASTER

A complete weather station with barometer, affordable enough for home use.



1990

2000

1996

New mounting allows you to install many sensors in one location.



1991 | WEATHERLINK

For the ultimate in weather monitoring, link any Davis weather station to an IBM-compatible PC or Macintosh.



1991 | PERCEPTION II

Monitor indoor climate using the most advanced technology available.



2000 | WEATHER ECHO

Take the weather with you wherever you go. The wireless Weather Echo receives and displays data from any of the Davis transmitters.



2001 | VANTAGE PRO

A sensor suite paired with the iconic Davis console. The console includes quick-view icons, graphing, and forecasts.



2004 | WINDSCRIBE

An ultrasonic wind meter that uses patented technology to read current wind speed.



2010

2009 | VANTAGE VUE

An accurate and reliable weather station that's tough, sleek, and sets up in minutes.



2008 | WEATHERLINKIP

Uploads data directly to WeatherLink.com without a PC.



2005 | VANTAGE PRO2 PLUS

A wireless, frequency-hopping, sensor suite that includes a 24-Hour Fan-Aspirated Radiation Shield, and Solar Radiation and UV Sensors.



2011 | VANTAGE CONNECT

A cellular telemetry data logger that provides remote, real-time weather and sensor readings.



2017 | AEROGONE

This rain collector reduces wind-induced errors with its aerodynamic design.



2017 | ENVIROMONITOR

Create a network of Davis and industry-leading, third-party sensors. View the data anywhere, anytime on WeatherLink.com and the Mobilize app.



2018

2019 | WEATHERLINK LIVE

WeatherLink Live connects to 80+ sensors at a time and live-streams data over Wi-Fi or Ethernet directly to the WeatherLink Cloud.



2018 | WEATHERLINK CLOUD PLATFORM

A suite of web, mobile, tablet, and API-based applications for viewing and managing personal weather data. Access real-time data anywhere, anytime and on any device.



Table of Contents

Weather Stations

P5

- Vantage Vue
- Vantage Pro2
- Weather station comparison
- How to upgrade Vantage Pro2
- Installing your weather station
- Why Davis Instruments

Data Collection

P14

- WeatherLink Live
- Vantage Connect
- EnviroMonitor Gateways
- WeatherLink data loggers
- Weather Envoy
- Data collection comparison

Data Viewing

P18

- WeatherLink data viewing
- WeatherLink Cloud
- WeatherLink Computer Software
- WeatherLink Cloud plans and pricing
- WeatherLink and Mobilize apps
- Station consoles

EnviroMonitor

P22

- Gateways and Node
- Davis and third-party sensors
- Mobilize app
- Integrated Pest Management
- WeatherLink.com
- EnviroMonitor installation app
- EnviroMonitor applications

Sensors & Accessories

P30

- Sensor Transmitters
- Wireless Leaf & Soil Moisture/Temperature Station
- Additional consoles
- Repeaters & antennas
- Sensor options
- Accessories

Tech Specs

P36

- Vantage console features
- Weather station tech specs
- Weather station compatibility
- Installation diagrams
- FAQs



Identifies the products that can be integrated with the EnviroMonitor system.



Identifies the stations or sensors that can be NIST traceable. See page 37 for details.



Sensor



Transmitter



Repeater
(optional)



Receiver



Software
(optional)



Identifies the products that can be integrated with the Sensor Transmitter.



Identifies the products that can be integrated with the Leaf & Soil Moisture/Temperature Station.

ISO 9001 CERTIFIED COMPANY

What's New?



New Tipping Spoon in Vantage Pro2 Products

Adds even greater rain accuracy

We've upgraded from tipping buckets to tipping spoons in all our Vantage Pro2 rain collectors. The new spoon increases our already-great accuracy from $\pm 4\%$ to $\pm 3\%$.



New EnviroMonitor IP Gateway

Send field data to the Cloud

Our newest Gateway collects data from EnviroMonitor Nodes via a mesh network, then sends it to WeatherLink.com via Wi-Fi (or Ethernet). Easily set up your IP Gateway and a network of sensors with the EnviroMonitor app. Compatible with all sensor suites. Check it out on page 23.



New Vantage Vue + WeatherLink Live Bundles

Everything you need in one bundle

Get both WeatherLink Live and a full Vantage Vue weather station (sensor suite and console), or choose a bundle with no console and access your data on your smartphone or WeatherLink.com. See the bundles (6110 & 6120) on pages 10-11.



New Sonic Anemometer

Measure wind with no moving parts

Upgrade your system to get instantaneous wind speed and direction using ultra sonic waves. No moving parts means even greater reliability. See it on page 33.

Weather Stations



Vantage Vue



Vantage Pro2



Measure Weather Where it Matters

Davis stations have been weathering storms and delivering accurate environmental data for over 30 years. Meteorologists, farmers, research scientists, backyard gardeners, and weather enthusiasts worldwide rely on our durable, precision instrumentation.

Vantage Vue®: Get serious about weather

Vantage Vue provides accurate, reliable weather monitoring in a self-contained, easy-to-install system. Sleek but tough, Vantage Vue gives you all the weather data you need:

- Inside & Outside Temperature
- Inside & Outside Humidity
- Barometric Pressure
- Rainfall
- Wind Speed & Direction
- Wind Chill
- Dew Point
- More

Your outdoor sensor suite sets up in minutes and transmits data wirelessly to your console anywhere in your home, school, or business. In addition to displaying current weather conditions and trends, Vantage Vue also boasts the innovative Weather Center that displays more information on weather variables over the last 25 days.

Features:

- Up to 10x faster updates than the competition (Every 2.5 seconds)
- Wireless transmission 3x farther than the competition (1,000 ft./300 m from station to console)
- Easy-to-read backlit screen
- Glow-in-the-dark keypad

1. TIME & DATE

View the current time and date, or time of sunrise/sunset.

2. MOON PHASE

Track the eight phases of the moon.

3. FORECAST

Icons let you know to expect sun, partly cloudy, clouds, rain, or snow.

4. TEMPERATURE & HUMIDITY

Console updates outside temperature every 10 seconds and inside temperature every minute. In addition, outside humidity updates every 50 seconds and inside humidity every minute.

5. RETRANSMITS

Console can extend range to additional consoles up to 1,000 ft. (300 m).

6. BAROMETER

Five-position trend arrow shows whether barometric pressure is rising, falling, or stable.

7. VARIABLE DISPLAY OPTIONS

See updated values every 10 seconds for heat index and wind chill to get a better “feel” for the outside environment.

8. RAIN

Console updates rain totals and rain rate every 20 seconds for the last 25 hours, days, and months.

9. “CHANGE IN WEATHER SINCE YESTERDAY” FEATURE

Allows comparisons of temperature and barometric pressure from day to day.

10. WEATHER CENTER

Weather Center provides additional information for each weather variable,

such as daily highs and lows, temperature changes by the hour, and barometric value changes. Also displays astronomical data.

11. USER-FRIENDLY KEYPAD

Domed buttons are easy to feel and press. Glow-in-the-dark keypad buttons give you access to weather information at night. The “DONE” key returns you to the “current” screen.

12. GRAPHS

Graphs the last 25 hours, days, or months. View up to 50 graphs for temperature, rain, rain rate, wind, and barometric pressure—all on the console.

13. “THIS TIME YESTERDAY” FEATURE

A data point on the graph indicates the weather during the same time yesterday to help compare and analyze day-to-day weather trends.

14. ALARMS

Set 22 simultaneous, different alarms to warn of dangers such as high winds, freezing temperatures, rain rate, heat index, flood warning, and more.

15. WIND SPEED

See wind speed updates every 2.5 seconds. Displays wind speed in miles per hour, meters per second, kilometers per hour, or knots. Provides the average and high wind speed for 2-minute and 10-minute intervals.



Rugged, accurate, affordable

The fully-integrated, corrosion-proof sensor suite is built to take all the weather your location can give—freezing winters, springtime thunderstorms, blistering summer sun, and brisk autumn winds. The small profile sensor suite is designed to minimize visual impact in your yard or on your roof.

6250 Vantage Vue



Pair with a data collection product (pages 14-17) to access data anywhere, anytime, and on any connected device with the WeatherLink Cloud.

1. WIRELESS

Frequency-hopping, spread-spectrum radio ensures consistent transmission up to 1,000 ft. (300 m) line-of-sight from sensor suite to console.

2. RAIN COLLECTOR

Self-emptying tipping spoon measures rain in 0.01" increments. Metric version measures in 0,2 mm increments.

3. ANEMOMETER

Wind tunnel-tested to 200 mph (320 km/h).

4. WEATHER-PROOF HOUSING

Corrosion-resistant cover provides durability in extreme conditions. Electronics are potted or overmolded for added moisture shielding.

5. RADIATION SHIELD

Provides excellent protection from solar radiation and other sources of radiated and reflected heat for accurate temperature and humidity readings.

6. TEMPERATURE & RELATIVE HUMIDITY

Provides outside temperature readings from -40° F to 150° F (-40° C to 65° C) and measures relative humidity from 1 to 100%.

7. EASY INSTALLATION

Installs easily and quickly with included mounting hardware kit.

8. WIND DIRECTION

Measures wind direction in compass points or degrees.

9. SOLAR PANEL

Energizes the station during the day. Onboard supercapacitor provides power at night. Lithium battery provides backup when needed.

10. BUILT-IN BUBBLE LEVEL

Allows for more accurate installation and better data collection.



6250 Vantage Vue



« The sensor suite mounts on poles from 1.00" to 1.75" (2,54 cm to 4,45 cm) in diameter (pole not included).

Vantage Pro2™: Professional and rugged

Vantage Pro2 and Vantage Pro2 Plus offer the professional weather observer or serious weather enthusiast robust performance with a wide range of options and sensors. You'll get your own local forecast, highs/lows, totals or averages, and graphs for virtually all weather variables over the past 24 days, months, or years—all on the console. Vantage Pro2 uses frequency-hopping, spread-spectrum radio to transmit and receive data up to 1,000 ft. (300 m) line-of-sight. Vantage Pro2 is also an excellent choice for emergency professionals, farmers, educators, researchers, municipalities, and others, to monitor wind and moisture conditions, irrigation requirements, and potential flooding.

Features:

- Up to 10x faster updates than the competition (Every 2.5 seconds)
- Wireless transmission 3x farther than the competition (1,000 ft./300 m from station to console)
- UV/solar radiation and evapotranspiration updates (Included with Vantage Pro2 Plus, optional for Vantage Pro2)
- Large, backlit 3.5" × 6" (9 × 15 cm) LCD screen

1. CURRENT & HISTORICAL DATA

View current data or highs and lows for up to 24 days, months, or years.

2. FORECAST

Icons let you know what to expect: sun, partly cloudy, rain, or snow. 12-hour icon forecast plus 24–48 hour ticker-tape forecast at the bottom of the console screen.

3. MOON PHASE

Track the eight phases of the moon.

4. TIME & DATE

View the current time and date, time of sunrise/sunset, time and date of highs/lows, and time and date of a graphed data point.

5. WIRELESS

Frequency-hopping, spread-spectrum radio provides three times the transmission distance of the competition, improved reception through multiple walls, and greater immunity from RF interference.

6. RETRANSMITS

Main console can retransmit to additional consoles up to 1,000 ft. (300 m).

7. BAROMETER

Five-position trend arrow shows whether barometric pressure is rising, falling, or steady.

8. FIXED DISPLAY

Fixed display area shows the outside temperature, humidity, and barometric pressure at all times.

9. SOLAR RADIATION

Included on Vantage Pro2 Plus. View current solar radiation, highs for the day, month, and year, as well as evapotranspiration and Temp/Hum/Sun/Wind (THSW) index. Set alarms for high readings.

10. UV

Included on Vantage Pro2 Plus. View current UV index, UV index for the day; the daily, monthly, and yearly highs; or change scale to see UV in current, hourly, and daily MEDs. Set alarm to warn of high UV dose/index.

11. VARIABLE DISPLAY OPTIONS

View inside or additional temperatures, humidity, soil moisture, UV index, leaf wetness, wind chill, dew point, and two different heat indices. (Additional sensors or stations may be required.)

12. RAIN

Umbrella icon appears when it is currently raining. View last 24 storm totals with start and end dates. View daily, monthly, or yearly rainfall and rain rate.

13. STATUS INDICATOR

Blinks to let you know that data packets are being received.

14. CONTROL KEYS

Use arrow keys to scroll through data on the graph or view highs and lows over time. "Plus" and "minus" keys simplify data toggling.

15. TICKER-TAPE DISPLAY

Provides expanded forecast details as well as additional information on current conditions. Displays more than 100 different messages.

16. GRAPHS

Graphs the last 24 hours, days, or months of readings; or highs and lows. View over 80 graphs, including additional analyses of temperature, rain, rain rate, wind, and barometric pressure.

Vertical scale changes depending on what you are graphing.

17. ALARMS

Set more than 70 alarms for multiple functions simultaneously.

18. WIND

Compass rose with 16 points shows current and dominant wind direction. Inside the compass rose, view wind direction to 1° resolution, or view wind speed.

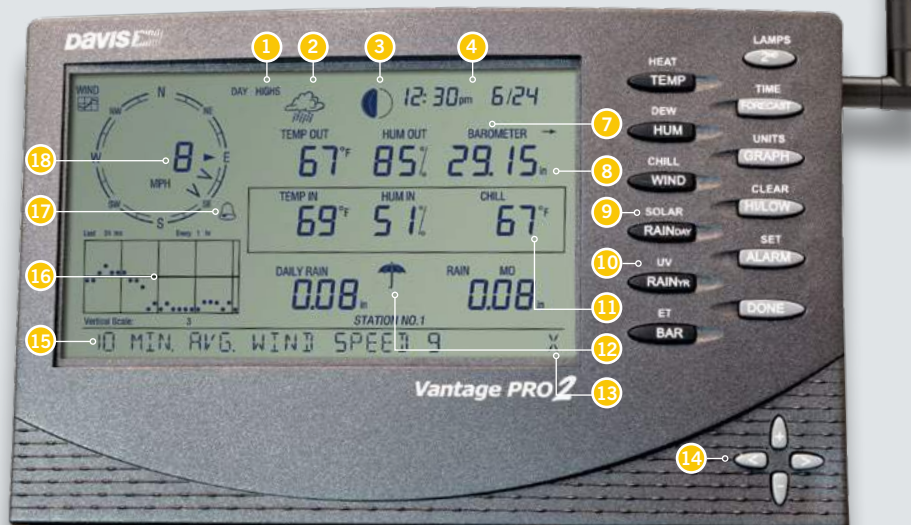

The ultimate in versatility and options

All Vantage Pro2 stations include a console and a versatile sensor suite (pictured below) that combines our rain collector, temperature and humidity sensors, and anemometer into one package. You can customize your Vantage Pro2 by adding extra consoles or the Sensor Transmitter options shown on page 31. Vantage Pro2 weather stations are available in both wireless and cabled versions. Vantage Pro2 Plus includes UV and Solar Radiation sensors; however, all stations can be customized with either.

Vantage Pro2 stations
(See pages 10-11 for models.)



Pair with a data collection product (pages 14-17) to access data anywhere, anytime, and on any connected device with the WeatherLink Cloud.

1. ANEMOMETER & WIND VANE

Rugged components stand up to hurricane-force winds, yet are sensitive to the lightest breeze. Wind tunnel-tested to 200 mph (320 km/h).

Anemometer can be installed separately using 40 ft. (12 m) cable (included).

Optional Sensor Transmitter allows you to mount the anemometer even farther from the rain collector and the rest of the sensor suite.

2. RAIN COLLECTOR

The patented AeroCone Rain Collector meets the collection area guidelines of the World Meteorological Organization. Reads rainfall amounts in 0.01" increments. Metric versions measure in 0,2 mm increments. Includes debris screen and spikes to keep birds from landing.

3. PASSIVE RADIATION SHIELD

The most effective passive shelter available. Protects your temperature and humidity sensors from solar radiation and other sources of radiated and reflected heat. Multi-plate construction for maximum airflow.

4. 24-HOUR FAN-ASPIRATED RADIATION SHIELD

Models with 24-Hour Fan-Aspirated Radiation Shields include additional radiation shield plates and a second solar panel to power the motor-driven fan.

5. TEMPERATURE & HUMIDITY SENSORS

Located inside the radiation shield, which protects the sensors from solar radiation and other sources of radiated and reflected heat.

6. WEATHER-RESISTANT SHELTER

Provides protection against the elements for the sensor suite's electronic components.

7. SOLAR PANEL

Powers the wireless station during the day and charges the supercapacitor for night operation. Lithium battery provides backup on cloudy days. (Solar panel is not included with cabled version.)

8. SOLAR RADIATION AND UV SENSORS (VANTAGE PRO2 PLUS)

Includes sensors to track solar radiation, evapotranspiration and UV indices. Time settings are programmable to meet your specific needs. Sensors can be added separately to the Vantage Pro2.

9. OPTIONAL MOUNTING POLE

One of several installation options. For more, including our mounting tripod, see page 12.



6152 Wireless Vantage Pro2. Includes built-in bubble level for accurate installation. The NEW tipping spoon in our rain collector is self-emptying, corrosion-resistant, and precisely-calibrated for exceptional accuracy.

See page 41-42 for installation diagrams.

Pictured: 6163 Wireless Vantage Pro2 Plus with 24-Hour Fan-Aspirated Radiation Shield

Weather Stations

Choose the configuration that's right for you. Buy a complete station with sensor suite and console, or as separates. Vantage Vue is also available bundled with WeatherLink Live.



Vantage Vue
Shown here: 6120

Vantage Pro2
Shown here: 6152

Vantage Pro2 Plus
Shown here: 6163

<p>Davis accuracy in a self-contained, easy-to-install system.</p> <p>Available bundled with WeatherLink Live.</p>	<p>Create a customized professional station with a wide range of options and sensors. Sensor suite has detachable anemometer for flexible siting.</p> <p>Choose a cabled station for the most economical installation where lightning risk is minimal. Choose wireless for easiest installation, additional sensor options and reduced risk of lightning damage.</p>	<p>Includes UV & Solar Radiation sensors.</p> <p>24-Hour Fan Aspiration model achieves maximum accuracy of temperature & humidity readings by circulating the air. Ideal for arid climates.</p>
--	--	---

The Davis line of Vantage weather stations is built to provide a full weather system. To maximize your weather watching, a variety of additional sensors and stations are available to make your weather station even more comprehensive.	6120 Wireless Bundle	6250 Wireless	6152C Cabled	6152 Wireless	6153 Wireless w/Fan	6162C Cabled	6162 Wireless	6163 Wireless w/Fan
CONSOLE								
Should be run using the included AC adapter. Add three C batteries (not included) for backup during power outages.			•			•		
May be run full-time using three C batteries (not included). May also be run using the included AC adapter.	•	•		•	•		•	•
12-hour advance forecast icons	•	•	•	•	•	•	•	•
24-48 hour advance forecast ticker-tape			•	•	•	•	•	•
Weather Center with scroll-through data screens	•	•						
SENSOR SUITE								
Anemometer, rain collector, temperature, and humidity sensors	•	•	•	•	•	•	•	•
Detachable anemometer with 40' (12 m) cable			•	•	•	•	•	•
Solar Radiation Sensor			Optional	Optional	Optional	•	•	•
UV Sensor			Optional	Optional	Optional	•	•	•
DATA TRANSMISSION								
100' (30 m) cable			•			•		
Solar-powered wireless transmitter with battery backup	•	•		•	•		•	•
RADIATION SHIELD								
Standard Radiation Shield	•	•	•	•		•	•	
Daytime Fan-Aspirated Radiation Shield			Optional	Optional		Optional	Optional	
24-Hour Fan-Aspirated Radiation Shield					•			•
WEATHERLINK LIVE								
WeatherLink Live	•	Optional		Optional	Optional		Optional	Optional
ADD-ONS								
Add console (or additional consoles) to view data in more than one location	Optional	Optional		Optional	Optional		Optional	Optional
Special-purpose Wireless Leaf & Soil Moisture/Temperature Station	Optional			Optional	Optional		Optional	Optional
Sensor Transmitter	Optional			Optional	Optional		Optional	Optional

Sensor Suites

Don't need a console? Your data can be pushed directly to the WeatherLink Cloud with a data collection device (pages 14-17) and a sensor suite that includes just the outdoor sensors. Sensor suites are a great choice for those who want to access their data only on their smartphone, tablet, or computer; or who want to integrate the sensor suite into an EnviroMonitor system. Choose from wireless or cabled, in a variety of options. (No console included.)



Vantage Vue Shown here: 6357		Vantage Pro2 Shown here: 6322			GroWeather Shown here: 6820		Vantage Pro2 Plus Shown here: 6328		
6110	6357	6322C	6322	6323	6820C	6820	6327C	6327	6328
Wireless Bundle	Wireless	Cabled	Wireless	Wireless w/Fan	Cabled	Wireless	Cabled	Wireless	Wireless w/Fan
	EM	EM	EM	EM	EM	EM	EM	EM	EM
SENSOR SUITE									
•	•	•	•	•	•	•	•	•	•
		•	•	•	•	•	•	•	•
		Optional	Optional	Optional	•	•	•	•	•
		Optional	Optional	Optional	Optional	Optional	•	•	•
DATA TRANSFER									
•	•	•	•	•	•	•	•	•	•
RADIATION SHIELD									
•	•	•	•	•	•	•	•	•	•
		Optional	Optional		Optional	Optional	Optional	Optional	
				•					•
WEATHERLINK LIVE									
•	Optional		Optional	Optional		Optional		Optional	Optional
ADD-ONS									
Optional	Optional		Optional	Optional		Optional		Optional	Optional
Optional			Optional	Optional		Optional		Optional	Optional
Optional			Optional	Optional		Optional		Optional	Optional

Three ways to upgrade your Vantage Pro2

1. Choose a wireless model

- Listen to up to eight channels of data.
- Use multiple consoles with one station.
- Move the console wherever you want.

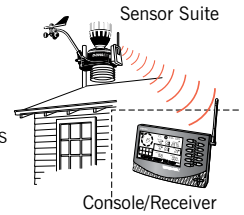

2. Choose a Plus model

- Solar and UV sensors come pre-installed.
- Console calculates ET
- Save money over buying separately.



3. Choose a model with 24-Hour Fan-Aspirated Radiation Shield

Models 6153, 6163, 6323, and 6328 include our 24-Hour Fan-Aspirated Radiation Shield for maximum accuracy of temperature and humidity readings. A motor-driven fan draws a constant airflow through the sensor chamber at 500 feet per minute (2,5 m/s). At night, when the effects of radiation are less, the solar-powered model runs on battery power and the airflow slows to 280 feet per minute (1,4 m/s). In far northern or southern latitudes, or in areas with extended periods of heavy cloud cover, there may not be enough sunlight to power the fan or recharge the battery during the winter. However, as the level of sunlight goes down, the need for fan aspiration also diminishes. The fan will start running and the battery will recharge as soon as sufficient sunlight returns.

NIST All consoles and all Vantage Pro2 Sensor Suites are NIST traceable.

Installing your weather station

Davis weather stations give you accurate data wherever they are installed. Whether you want to know the temperature on your back deck, are concerned about the wind speed in your garden, or want to report your data to NOAA, Davis weather stations can be installed to perfectly suit your needs.



Vantage Pro2 on Mounting Tripod

Mounting Tripod

This galvanized steel tripod with tilting brackets makes for easy installation anywhere, even on a roof or uneven surface. Perfect for mounting any sensor suite, Vantage Connect or EnviroMonitor Gateway/Node. Poles measure 36.38" (0,92 m) long. Assemble the two together to make a single 69.75" (1,77 m) pole. Outside diameter is 1.31" (33 mm). For ground installation use 7716A, which includes three 18" (0,46 m) lag bolts.

7716 Mounting Tripod



7716A Mounting Tripod

with 18" (0,46 m) lag bolts



Mounting Pole Kit

Ideal for mounting a sensor suite, Vantage Connect, or EnviroMonitor Gateway/Node to a preexisting structure such as a deck, a fence post, or roof eaves. Includes two galvanized steel poles, connector, and mounting hardware. Poles measure 19.5" (0,50 m) and 21" (0,53 m) long. Assemble the two together to make a single 37.5" (0,95 m) pole. Outside diameter is 1.31" (33 mm). Includes mounting hardware.

7717 Mounting Pole Kit



Vantage Vue on Mounting Pole

Installation Guidelines

Mount your Vantage Vue or Vantage Pro2 Sensor Suite:

- 5-7 feet (1,5-2,1 m) above the surface (ground or roof).
- Over a flat area that is gently sloping, regularly mowed, or naturally landscaped, with good drainage.
- Away from heat radiators, such as asphalt or air conditioning units.
- Where you can access the rain collector for maintenance.
- At least 2 feet (0,6 m) above the average maximum yearly snow depth.
- So that the anemometer is not blocked by surrounding obstructions such as trees or buildings.
- The Vantage Pro2 anemometer can be extended from the station with the 40' (12 m) included cable, or by combining with a Sensor Transmitter. (See page 31 for options.)



Join the Davis Community: **Hundreds of thousands of stations around the world with common goals: accuracy, durability, and dependability**

Why Davis Instruments:

When you purchase a Davis Instruments weather station, you join a community of weather enthusiasts and professionals around the world that are committed to collecting, analyzing, and sharing accurate weather data. Our products are meant to withstand the harshest environments and many of our customers have enjoyed their stations for over a decade with minimal routine maintenance.

Made by "US"

Our products are designed, assembled, and rigorously tested by the Davis team at our headquarters in Hayward, California.

Durability

Our weather stations go through a minimum of 10 tests before shipping. They have been engineered to withstand corrosion, 200 mph (90 m/s) winds, the scorching sun, and extreme temperatures.

Precision & Accuracy

Our products provide scientific-grade precision and accuracy. We have spent decades improving and refining every sensor that we make.

Value

Our products are designed to provide professional-grade instruments at an affordable price. You can find a cheaper station, but you won't be disappointed by a Davis station.



WeatherLink Network: The Davis online community

Join the WeatherLink Network by connecting your weather station to the WeatherLink Cloud to access your data anywhere, anytime, on WeatherLink.com and the WeatherLink mobile app.

See pages 19-21 for more information.

Data Collection

Your Data, Your Way

Staying connected to your weather conditions is critical. Davis offers a wide array of data collection options to keep the data coming. No matter if it's from your backyard, the back forty, or the back woods, we've got you covered.



WeatherLink Live
Wi-Fi/Ethernet



Vantage Connect
Cellular



EnviroMonitor Gateway
Cellular+Mesh Network



EnviroMonitor IP Gateway
Wi-Fi/Ethernet+Mesh Network



WeatherLink USB/Serial
Computer

WeatherLink Live™ : A smart way to stream live data

WeatherLink Live makes getting your data from any Davis sensor simple, reliable, and fast. This data hub uses Davis's dependable, frequency-hopping, spread-spectrum radio to collect data from your weather station and a network of indoor and outdoor sensors. Access your data from the WeatherLink Cloud on the website and mobile apps.

Monitor YOUR environment

Configure a custom network of multiple Davis sensors with one WeatherLink Live.

Track barometric pressure and inside temperature and humidity.

Add any combination of up to eight of the following:

- Vantage Vue Sensor Suites
- Vantage Pro2 Sensor Suites
- Sensor Transmitters with up to five sensors (pages 31-35)
- Wireless Leaf & Soil Moisture/Temperature Stations (page 31)

Welcome to the smart home

- Ask Amazon Alexa or Google Assistant about your weather.
- Connect your data to smart irrigation systems or other IoT/smart home devices.

Securely share your data

- Contribute your weather data to the global WeatherLink community.
- Share data with friends, family, or co-workers via the WeatherLink website and mobile applications.
- Upload to a growing list of third-party sites like Weather Underground or CWOP.
- Build your own weather tools with our powerful suite of API products.

Enjoy real-time data

- Experience the fastest reporting weather data on the market with any personal device.

Never lose data

- Safeguard recorded data with WeatherLink Live's internal auxiliary memory.
- Protect against data loss with redundant battery backup.



Effortless setup

- Simple setup using the WeatherLink app and your phone's Bluetooth function.
- No Wi-Fi? No problem. Easily connect to Ethernet with the included cable.

Long-range wireless data

- Depend on Davis's industry-leading, proprietary, frequency-hopping, spread-spectrum radio to transmit data up to 1,000 ft. (300 m), line-of-sight.



80+	10+
Connected sensors to one WeatherLink Live	Different sensor types
8	1,000 ft.
Listen to 8 transmitters	(300 m) Transmission distance
	
Stream live data	Just ask Amazon Alexa or Google Assistant

Note: WeatherLink Live is not compatible with WeatherLink Computer Software.

Comes Wi-Fi ready, with a 6.5 ft. (2 m) power cable and a 5 ft. (1.5 m) Ethernet cable.

6100 WeatherLink Live

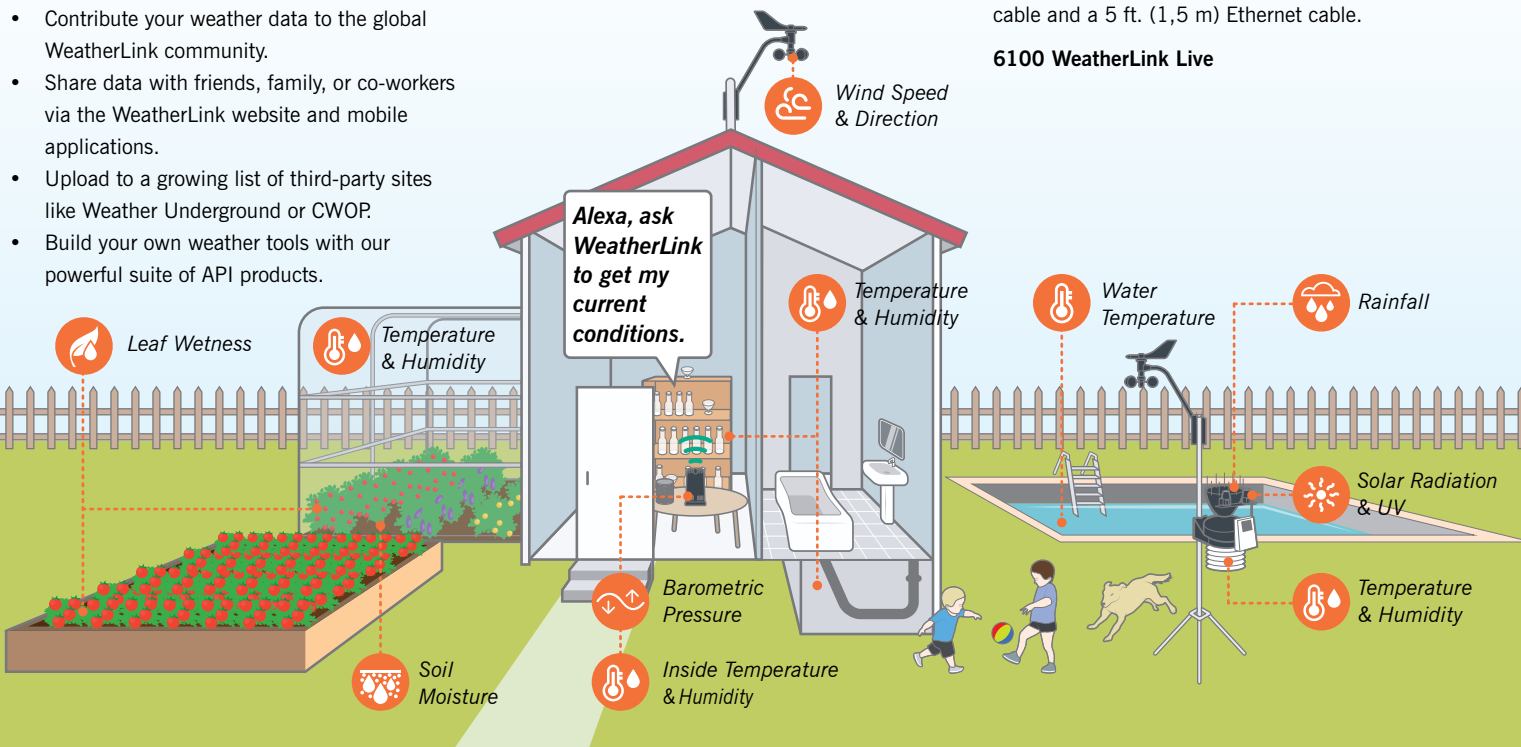

Remote cellular telemetry solutions

Vantage Connect and the EnviroMonitor Gateway combine cellular technology with an integrated data logger to transmit real-time sensor data to the WeatherLink Cloud. From there, you can view data on WeatherLink and Mobilize apps.

These units are self-contained, weather-resistant, and powered by a 5-watt solar-panel. They include a 6-volt rechargeable battery and come with mounting hardware.



Vantage Connect/
EnviroMonitor Gateway

Vantage Connect: Single Point Cellular Solution

1

Vantage Vue or
Vantage Pro2

8

Maximum number of
Davis transmitters

1,000 ft.

(300 m)
Transmitter to
Vantage Connect

Wireless
Point-to-Point
Network
Communication

Davis
Compatible Sensors

- Perfect for collecting weather and sensor data in remote locations.
- Combine up to eight Davis transmitters configured with a selection of Davis sensors.
- Compatible with both wireless and cabled sensor suites.

6622 Vantage Connect, 2G/3G

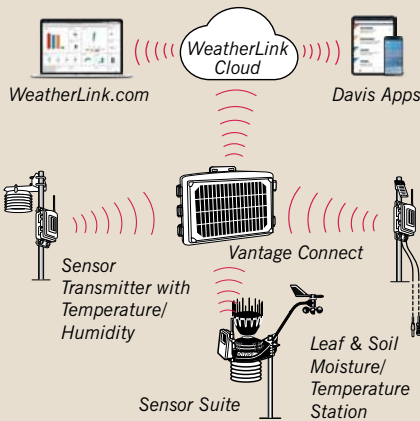

EnviroMonitor Gateway: Expandable Cellular Mesh Network

1

GroWeather or
Vantage Pro2

25+

Maximum number of
EnviroMonitor Nodes

10,000 ft.

(3,000 m)
Node to Gateway
with 8 dBi Antenna
(page 32)

Wireless
Mesh Network
Communication

Davis &
Third-Party
Compatible Sensors

Bluetooth enabled

- Perfect for building a flexible network with multiple sensors.
- Connects with 25+ Nodes, each with up to four sensors.
- Compatible with cabled sensor suites.
- Compatible with Davis and industry-leading, third-party sensors.
- Simple setup using the EnviroMonitor app and your phone's Bluetooth function.

See pages 22-29 for more information on EnviroMonitor.

6801 EnviroMonitor Cellular Gateway

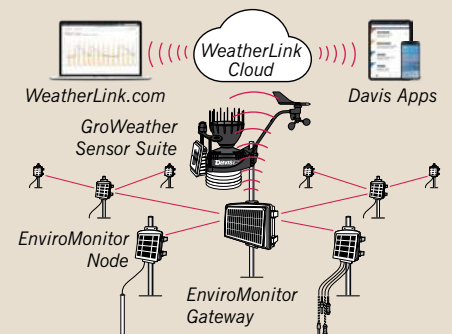

Annual Service Plan

Each Vantage Connect and EnviroMonitor Gateway/Node requires an Annual Service Plan. Annual subscriber fees depend on the selected update interval frequency. The Vantage Connect and EnviroMonitor Gateway require a one-time activation fee (#6645).

VANTAGE CONNECT			ENVIROMONITOR GATEWAY & NODES				
Update Interval	Annual Service Charge/ Product Number Per Vantage Connect		Update Interval	Annual Service Charge/ Product Number Per Gateway		Annual Service Charge/ Product Number Per Node	
5 minutes	Call	6632A	5 minutes	Call	6892	Call	6882
15 minutes	Call	6634A	15 minutes	Call	6894	Call	6884
60 minutes	Call	6636A	60 minutes	Call	6896	Call	6886

WeatherLink USB and Serial Data Loggers

The USB and Serial Data Loggers connect the console to a computer running WeatherLink Computer Software. Optionally upload data to the WeatherLink Cloud with an internet-connected computer that is on and running the software. Free WeatherLink Computer Software is available for download on WeatherLink.com.

6510USB USB Data Logger
6510SER Serial Data Logger



Data loggers compatible with Vantage Vue and Vantage Pro2 consoles.

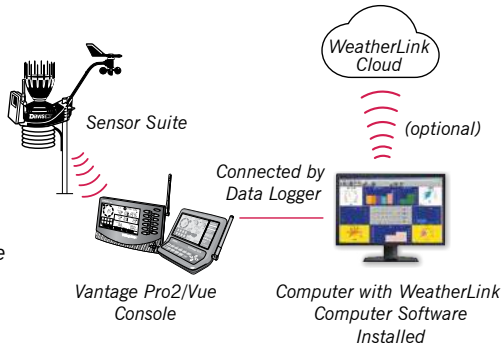

Weather Envoy™

Receive data from a Vantage Pro2 Sensor Suite, a Vantage Vue Sensor Suite, or other Sensor Transmitters. Use with a required WeatherLink data logger to push data securely to the WeatherLink Cloud and access it for FREE on WeatherLink.com and the WeatherLink Mobile app. From there you can view, share, compare, and download data. With WeatherLink Computer Software and a data logger, you can collect and store data from the outdoor sensors and download it directly to your computer.

6316 Wireless Weather Envoy
6316C Cabled Weather Envoy



Use the data collection device that's right for you



WeatherLink Live



WeatherLink USB



WeatherLink Serial



Vantage Connect



EnviroMonitor Gateway



EnviroMonitor IP Gateway

	WeatherLink Live	WeatherLink USB	WeatherLink Serial	Vantage Connect	EnviroMonitor Gateway	EnviroMonitor IP Gateway
Data transmission	Wi-Fi/Ethernet	USB	Serial	Cellular	Cellular	Wi-Fi/Ethernet
Data upload to WeatherLink Cloud requires computer and software running 24/7	No	Yes	Yes	No	No	No
Streams live data within LAN	Yes	No	No	No	No	No
Typical installation location*	Indoor	Indoor	Indoor	Outdoor	Outdoor	Indoor/Outdoor
Console or Envoy required	No	Yes	Yes	No	No	No
Storage capacity**	180 days	26 days	26 days	26 days	180 days	180 days
Power source	AC/battery back-up	AC/battery via Console/Envoy	AC/battery via Console/Envoy	Solar/battery back-up	Solar/battery back-up	AC/battery back-up
Annual service plan required	No	No	No	Yes	Yes	Yes
Product Number	6100	6510USB	6510SER	6622	6801	6805

*WeatherLink Live, WeatherLink USB, and WeatherLink SER are intended for indoor use. To use an EnviroMonitor IP Gateway outdoors, mount in a Universal Shelter, 6618. (See page 34.)

**Based on data from one sensor suite at a 15-minute archive interval.

Data Viewing

Choose Your View

Access, analyze, share, and compare your weather data from any connected device, console, or desktop computer. Customize your bulletin dashboard of current conditions, use forecasts, chart historical data, and share your data with the WeatherLink Network and beyond.



WeatherLink.com
Web



WeatherLink
Mobile App



Mobilize
Mobile App



WeatherLink
Computer Software



Console

WeatherLink: Best-in-class meteorological data viewing

Our data-viewing options give you access to WeatherLink.com and apps from anywhere on any device via the WeatherLink Cloud or by downloading the WeatherLink Computer Software directly to your computer. You can also combine these two options. Both options are completely FREE, with the ability to upgrade based on your data needs. Pair your software needs with a compatible data-collection device to view and record weather and sensor data.

WeatherLink Cloud

The WeatherLink Cloud family of products offers the ultimate in versatility for access to your data. With the completely FREE Basic tier you can view current conditions on WeatherLink.com or the WeatherLink Mobile app anywhere, on any internet-connected device.

Upgrade to a Pro or Pro+ account for access to all historical data, charting, and raw data exports for a full-featured analysis tool.

WeatherLink Cloud is compatible with all Davis data-collection products. See page 17 for details.



WeatherLink Computer Software

The FREE WeatherLink Computer Software is available for download with a FREE WeatherLink.com account. It allows you to store data directly on your computer's hard drive. The software package includes the ability to graph multiple variables and export data to popular spreadsheet and database programs.

Use an internet-connected computer turned on 24/7 to share data with the WeatherLink Cloud for FREE. (Data logger required.)

WeatherLink Computer Software is not compatible with Mac OS Catalina and forward.



	WeatherLink Cloud Access your data from any connected device	WeatherLink Computer Software Access from a single computer, optionally connect to WeatherLink Cloud
WeatherLink Live	Automatically sends data to WeatherLink Cloud.	Download data from WeatherLink Cloud to Computer Software.
Vantage Connect	1 3	<i>WeatherLink Computer Software is not compatible with WeatherLink Live.</i>
EnviroMonitor Gateways		
WeatherLink USB/Serial Data Logger	Optionally upload data to WeatherLink Cloud for FREE. (Data logger cabled to an internet-connected computer running 24/7)	Data stored and analyzed in WeatherLink Computer Software.

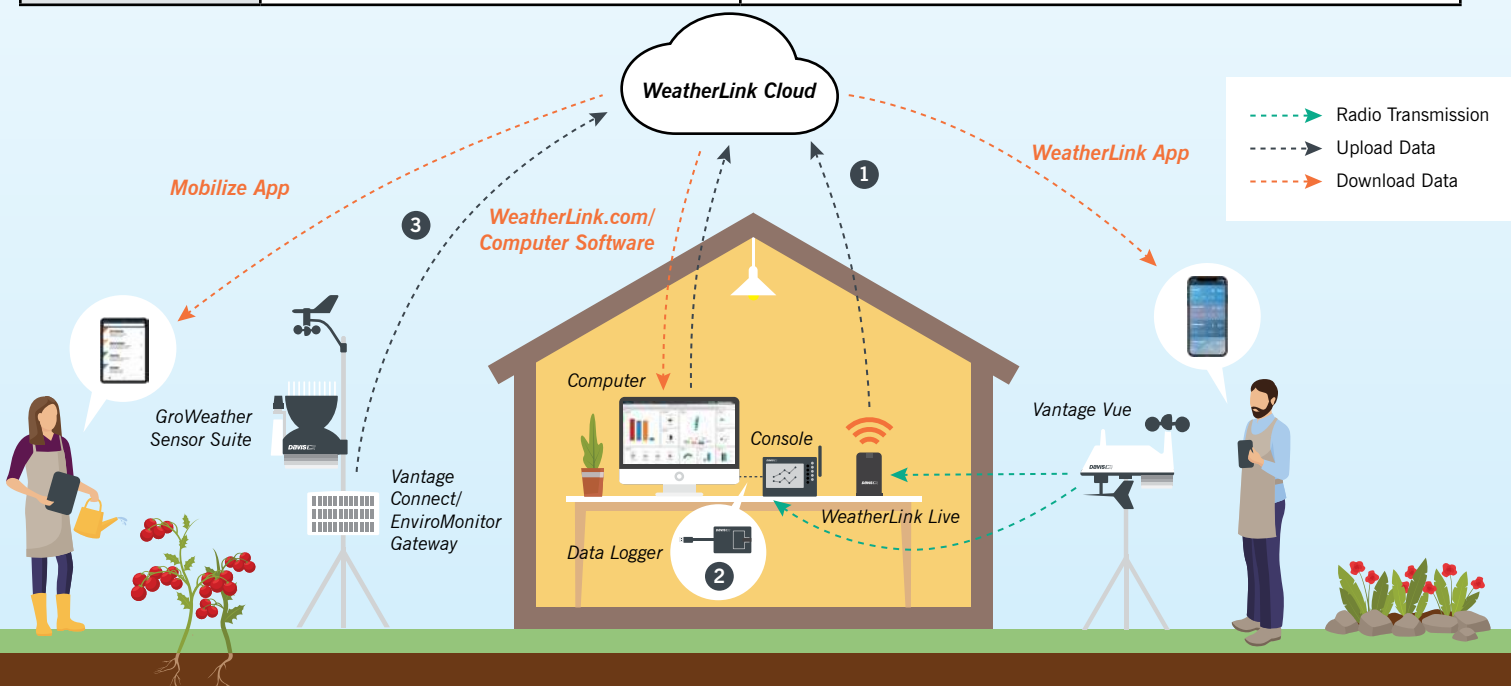

WeatherLink.com: All of your data, on the web

© 2018 Google

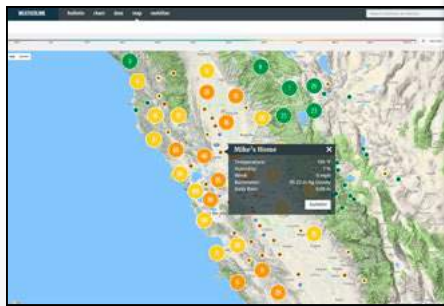

View current conditions bulletin dashboards from the global WeatherLink Network of public stations. **Free with Basic**



Build a custom weather view on the bulletin dashboard. **Free with Basic**

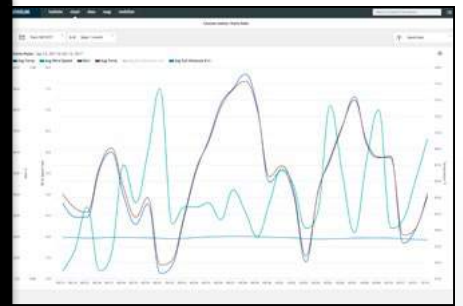

Use the chart feature to compare multiple weather data variables at the same time. **Upgrade to Pro or Pro+**

WeatherLink Basic

With the completely FREE WeatherLink Basic account you get a versatile tool to monitor current conditions at home or around the world.

- Create a custom bulletin dashboard of current conditions with 16+ different data types.
- Share a secure station URL for anyone to view your weather data. No account required to view.
- View local weather forecasts.
- Access the global WeatherLink Network of public stations on the map.
- Upload data to third-party sites, like Weather Underground and CWOP.
- Get e-mails and text alerts with preset alarms.
- Use the API to access weather data in XML or JSON formats.

WeatherLink Pro

Enhance your WeatherLink experience by upgrading to Pro.

- Visualize multiple data points at once with historical data in charts.
- Analyze and download all raw data records.
- Increase data speeds for third-party uploads and WeatherLink API usage.
- Pro share a station to give Pro capabilities to up to six friends or colleagues.
- Use Mobilize web and mobile tools for smart farming and gardening.

WeatherLink Pro+

- Take advantage of the fastest third-party uploads and API usage.
- Protect crops and gardens with our Integrated Pest Management tool.



WeatherLink App

View your current and forecast conditions from your station and the WeatherLink Network of public stations around the world, all from a mobile phone or tablet.

FREE with WeatherLink Basic.

Search "Davis WeatherLink Mobile" on iOS and Android app stores.



Mobilize App

Developed to help commercial growers with critical decisions, Mobilize gives any farmer or sophisticated gardener the power to track site-specific conditions related to irrigation, weather, frost, pest management (Pro+), and more.

See pages 26-27 for details.

Upgrade to Pro or Pro+ to use Mobilize.



WeatherLink.com: Plans and pricing

	BASIC	PRO		PRO+	
	\$0/mo	1-year Plan, 6561 Call	3-year Plan, 6561A Call	1-year Plan, 6562 Call	3-year Plan, 6562A Call
¹ Bulletin Data Tiles	✓		✓		✓
² Data Viewing & Export	✗		✓		✓
³ WeatherLink Network Map	✓		✓		✓
⁴ Custom Charting	✗		✓		✓
⁵ Integrated Pest Management	✗		✗		✓
⁶ WeatherLink App	✓		✓		✓
⁷ Mobilize App	✗		✓		✓
⁸ Pro Shares	0		6		10
⁹ Third-party Upload Rate	15 minutes		5 minutes		Up to 1 minute

1. Bulletin Data Tiles: Build and customize your bulletin dashboard to display current data updates from all of your installed sensors. You can move and resize tiles to see the data just the way you like it.

2. Data Viewing & Export: Access all of your raw sensor data at the click of a button. You can sort by date/time or data type and export any data set directly to an Excel-friendly .csv file.

3. WeatherLink Network Map: Use the WeatherLink map to view and interact with the community of public stations in our worldwide WeatherLink Network. Click on a station to see a summary of current data and click "bulletin" to see the station's customized weather dashboard.

4. Custom Charting: Visualize any of your sensor data with custom line and bar charts on up to four different y-axes. Zoom into an hour of data or out to a full year to view details and trends.

5. Integrated Pest Management: Access Integrated Pest Management (IPM) on Mobilize to link your weather and sensor data to actual pest risk, giving you a powerful new tool in protecting your crops from pest damage.

6. WeatherLink App: View your current and forecast conditions from your station and the WeatherLink Network of public stations around the world, all from a mobile phone or tablet.

7. Mobilize App: Use the Davis Mobilize app on iOS or Android to create custom frost, weather, crop, IPM, and irrigation reports to view on WeatherLink.com and mobile. It's robust enough to protect your farm crop from frost—and fun for the data-savvy backyard gardeners looking to perfect their tomato crop.

8. Pro Shares: Pro Share your device to give another user access to historical data and charting.

9. Third-Party Upload Rate: This is the rate at which you can upload your device's data to a third-party site such as Weather Underground or CWOP, and every data from the WeatherLink API.

Pro upgrade is included with a Vantage Connect or EnviroMonitor Gateway Service Plan.

Vantage Consoles: Dynamic data-visualization tools

These industrial-grade consoles are loaded with features far beyond any other on the market. They display current conditions, have a user-friendly keyboard with a backlit screen, allow you to graph up to 80 different parameters and set up to 70 different alarms simultaneously. See page 32 for details.



6312 Vantage Pro2 Console



6351 Vantage Vue Console

6351 Vantage Vue Console/Receiver

6312 Wireless Vantage Pro2 Console/Receiver

EnviroMonitor®



Gateways



Nodes



Sensors



Mobilize

Measure, Monitor, and Manage

Easy to install, affordable, and third-party sensor compatible. Track site-specific weather and use the easily expandable EnviroMonitor system to build a custom network of sensors to help make critical crop decisions.

EnviroMonitor: Make critical decisions from anywhere at anytime

EnviroMonitor is a simple and cost-effective way to get critical field data continuously transmitted from the field to your mobile devices or computer. Get the timely and meaningful information you need to manage your crops, reduce risks, and save money.

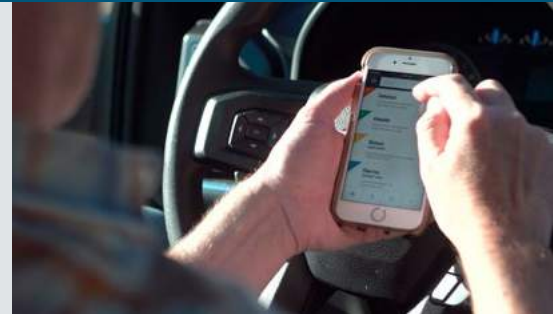

EnviroMonitor Gateways

EnviroMonitor Gateways collect all essential data from the Nodes and push it securely to the WeatherLink Cloud via either cellular connectivity, Wi-Fi, or Ethernet. The data can then be accessed on your phone, tablet, and computer. Mounting hardware is included. Requires an Annual Service Plan and a one-time activation fee. (See Annual Service Plans on page 29 for details.)

EnviroMonitor Gateway

Cellular+Mesh Network

Solar-powered Gateway uploads using cellular connectivity. Includes a 5-watt solar panel and a rechargeable 6-volt backup battery encased in a weather-resistant housing. Works with EnviroMonitor Nodes and any cabled sensor suite.



6801 EnviroMonitor Cellular Gateway

New EnviroMonitor IP Gateway

Wi-Fi/Ethernet+Mesh Network

The IP Gateway uploads via Wi-Fi or Ethernet. AC-powered with 4 AA batteries (not included) for backup. Includes AC adapter and optional Ethernet cable. Mount indoors or outdoors with a Universal Shelter (6618). (See page 34.) Works with EnviroMonitor Nodes and any wireless or cabled sensor suite.



6805 EnviroMonitor IP Gateway

EnviroMonitor Nodes

Nodes connect over a self-optimizing mesh network and transmit critical sensor data to the EnviroMonitor Gateway. Nodes communicate with each other, allowing complete network flexibility around barriers and across distances. Each EnviroMonitor network can host 25+ Nodes. The solar-powered Node is self contained and weather resistant. Includes a 3-watt solar panel and mounting hardware.

Node Features

- Connect up to 4 sensors to each Node
- Communication range: Up to 10,000 ft. (3,000 m), Node-to-Node and Node-to-Gateway with 8 dBi Long-Range Antenna (7678).
Note: Range varies with terrain and environment. (See page 32.)
- Configures easily with a smartphone
- Rechargeable lithium-ion battery (included) powers the unit at night
- 4 D-cell batteries (not included) provide backup
- Optional AC adapter (6714) (see page 35.)



6810 EnviroMonitor Node

Never miss a sensor reading. EnviroMonitor uses a secure, self-optimizing mesh network to make sure you always get your data.

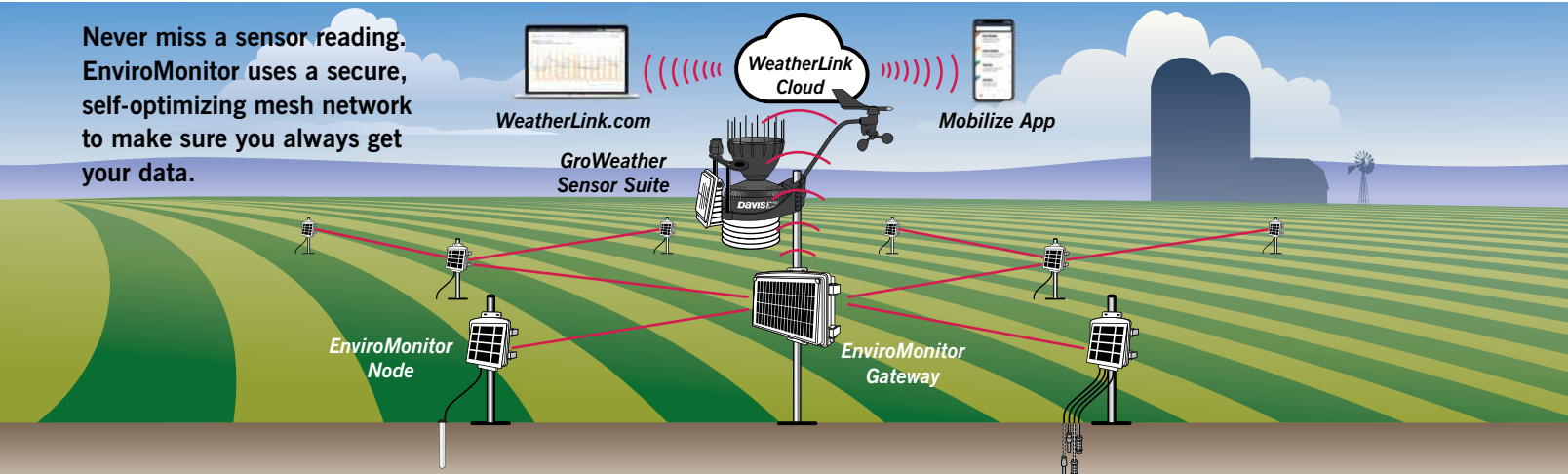

Easily Expandable: EnviroMonitor is compatible with hundreds of different Davis and third-party sensors



GroWeather 6820C

- Temperature & Humidity
- Wind Speed & Direction
- Rainfall & Rain Rate

EnviroMonitor Gateway

- UV
- Solar Radiation
- Barometric Pressure via Gateway

Calculations include:

- Dew Point
- Wind Chill & Heat Index
- Evapotranspiration
- Wet Bulb

It all starts with the weather

Connect a Davis Sensor Suite to the Gateway to get all the benefits of complete weather monitoring. These rugged, low-maintenance sensor suites are available with Solar and/or UV Sensors and a variety of radiation shield options. The IP Gateway can pair with any sensor suite, while the cellular Gateway works with any cabled sensor suite.

See pages 10-11 for sensor suite details.

Expand effortlessly with Davis and third-party sensors

Each Node can support up to four sensors from Davis and other leading sensor manufacturers. EnviroMonitor is an open-sensor platform that is compatible with hundreds of industry-leading sensors from the manufacturers you know and trust.

See pages 33-35 for Davis sensors.



- Soil Moisture
- Soil Temperature
- Soil Salinity
- Water Level
- Leaf Wetness
- Weight
- Pressure Sensor
- Pressure Switch
- Flow Meter
- Solar Radiation
- PAR (PPFD)
- Temperature & Humidity
- Temperature
- Wind Speed & Direction
- Rainfall
- Carbon Dioxide

Compatibility

EnviroMonitor is compatible with SDI-12, analog voltage (i.e. 0-3V; 0-5V; 0-12V), contact closure, pulse, and I2C sensors. We are constantly integrating new sensors to expand the capabilities of the EnviroMonitor platform and software.

Please contact us if you would like a sensor added.

Supported Sensors: www.davisinstruments.com/em-sensors



Easy to Install



Install and manage your entire EnviroMonitor sensor network with Davis Instruments' EnviroMonitor iOS and Android app. **Download for FREE!**

See page 27 for more information on the EnviroMonitor app.

Measure, Monitor, and Manage



Track all of the data from your EnviroMonitor sensor network with Davis Instruments' Mobilize iOS and Android app. **Download for FREE!**

See pages 26-27 for more information on the Mobilize app.

Use Case: Getting to the root of the issue

Located in California's beautiful Livermore Valley, this historic boutique winery was built in 1889 and is still producing award-winning wines.

To help use resources wisely and reduce the damage brought on by environmental conditions, they installed an EnviroMonitor system and have been acting on the data since 2018.

The system includes:

- 1 EnviroMonitor Gateway (6801)
- 1 GroWeather Sensor Suite (6820C)
- 4 EnviroMonitor Nodes (6810)
- 3 Watermark™ Soil Moisture Sensors (6440)
- 1 Leaf Wetness Sensor (6420)
- 1 Temperature/Humidity Sensor (6830)
- 2 Sentek™ Soil Moisture Probes
- 4 Gems™ Pressure Switches
- 1 Decagon/Meter™ Soil Moisture Sensor
- 1 Aquacheck™ Soil Moisture Probe

Water is a precious resource in California. With pressure switches and soil moisture sensors, the grower knows when the irrigation system is on and runs it only long enough to penetrate the vines' roots. The Leaf Wetness and Temperature/Humidity Sensors give the team insights on conditions where the grapes are growing. With forecasted data in hand, they can take actions to reduce damage caused by frost, freezing conditions, and heat while tracking chill portions, growing degree days, ET, and much more.

With this installation, the team has the data they want and the ability to add additional Nodes and sensors when they're ready.

The Fenestra Winery installation has been made publicly available for viewing on WeatherLink.com. Search for "Fenestra Winery" and click "bulletin" to view a selection of weather sensors.



Temperature/Humidity Sensor (6830)



Leaf Wetness Sensor (6420)



Gems Pressure Switch

EnviroMonitor Gateway

GroWeather Sensor Suite 6820C

Mobilize: Critical field data delivered to your mobile phone

Mobilize is an agriculture-focused, decision-making app with some of the latest advancements in agronomy. You can easily create custom views of your farm, receive alerts, and browse sensor data to track specific report conditions related to weather, frost, irrigation, growth cycle, pest management, and more.

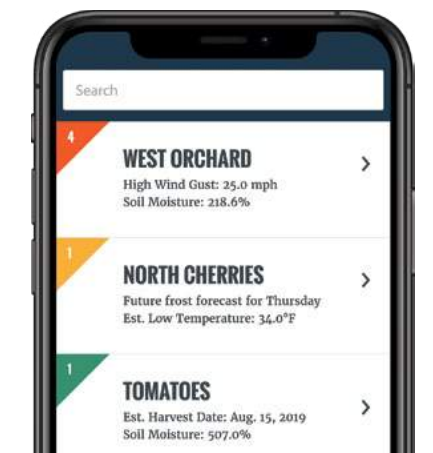

Mobilize Home

See custom views of your fields or crops.

- Color-coded flags alert you immediately to conditions that require your attention.
- Click through for more information on each view.



Irrigation Management

Track soil moisture levels to know when, where, and how much to irrigate.

- Custom soil moisture thresholds
- Irrigation alerts
- Evapotranspiration (ET) data
- Past and forecast rain totals

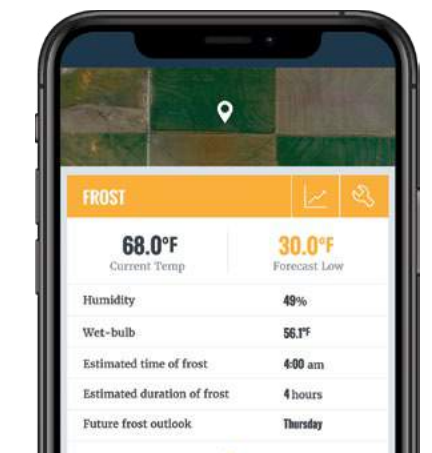

Frost Tracking

Precise forecasting allows you to stay ahead of critical conditions.

- Forecast frost conditions
- View real-time temperature threshold alerts
- Wet-bulb temperature and humidity tracking

WeatherLink.com: Your field data, your way

WeatherLink.com is the web-based portal for accessing all of your EnviroMonitor data. The website displays reports created in Mobilize and provides more ways to utilize your sensor data.

- Build a custom bulletin dashboard of visual data tiles to track key current conditions.
- Visualize any combination of field data in the chart section.
- Analyze all of your system data in the data section, or export the data into spreadsheet-compatible formats.
- Set custom alerts for specific sensors or calculated conditions.
- Generate and share a daily data summary with anyone on your team.
- Securely share field data with colleagues.

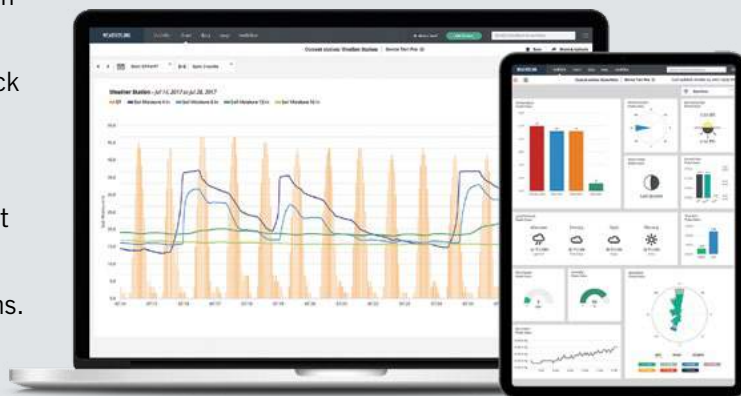

Forecasting Solutions: Make decisions before problems occur

Mobilize integrates forecasts into reports to help predict growing degree days for harvest, forecast frost conditions before they occur, and estimate future rain to help save water. Decisions are easier when you know what is coming.



Crop Management

Track key growing degree day (GDD) and chill requirements against custom targets by crop type.

- Chill and growing degree day progress tracking
- Integrated forecasts for planning

Weather Monitoring

Improve daily decisions with real-time field conditions that help you plan with confidence.

- Spray effectively with location-specific wind data
- Document extreme temperature conditions
- Collect in-field rain data

Integrated Pest Management

Monitor pest/disease models specific to a long list of crops.

- Track Pest Risk Index
- Update IPM models with remediation actions
- Track past, current, and future pest stages

Temperature, humidity and leaf wetness sensors and Pro+ WeatherLink upgrade required.

EnviroMonitor: Effortless configuration

The EnviroMonitor configuration app is used to easily install, monitor, and interact with your EnviroMonitor hardware and sensor systems.

- Securely connect to Gateways and Nodes with your phone via Bluetooth.
- Easily install and modify sensor configurations on Gateways and Nodes.
- Quickly determine mesh network and Gateway cellular connection strength.
- Remotely identify and troubleshoot any sensor issues.
- Share system access with team members to allow the ability to modify or view specific systems.

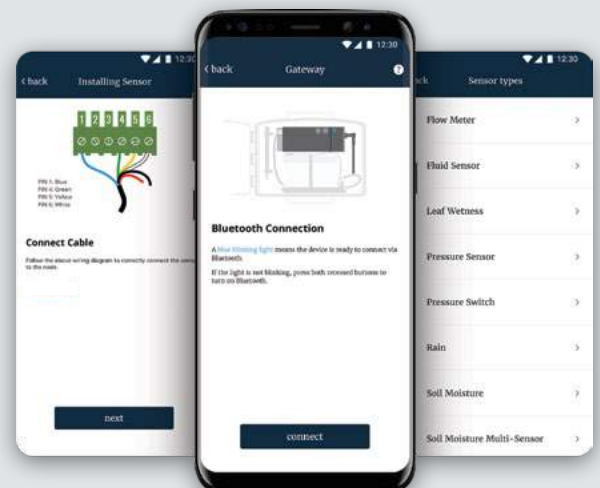

EnviroMonitor for any application

Build your own or pick from our application-specific systems. No matter how you configure your system, EnviroMonitor provides more features for a lower cost than the competition.



	My Farm, My Weather Monitor field specific weather	IPM System Monitor weather and manage pest conditions	Inversion System Monitor weather and inversion conditions for frost and spray drift
Sensors and Hardware	<ul style="list-style-type: none"> • EnviroMonitor IP Gateway (6805) • GroWeather Sensor Suite (6820) 	<ul style="list-style-type: none"> • EnviroMonitor Gateway (6801) • EnviroMonitor Node (6810) <ul style="list-style-type: none"> - Leaf Wetness Sensor (6420) • GroWeather Sensor Suite (6820C) 	<ul style="list-style-type: none"> • EnviroMonitor Gateway (6801) • EnviroMonitor Node (6810) <ul style="list-style-type: none"> - 2 Temp/Hum Sensor w/Radiation Shield (6830) • GroWeather Sensor Suite (6820C)
Annual Service Plan <i>(15-minute interval)</i>	-	-	-
Activation Fee	-	-	-
EnviroMonitor First Year Price	Call	Call	Call
Mobilize Reports & Agricultural Applications	Farm Weather: <ul style="list-style-type: none"> • Rainfall • Frost Alarms • Growing Degree Days • Chill Requirements • Evapotranspiration • Wind Speed & Direction 	Farm Weather Plus: <ul style="list-style-type: none"> • Leaf Wetness • Integrated Pest Management <i>(Requires Pro+ Account)</i> 	Farm Weather Plus: <ul style="list-style-type: none"> • Inversion monitoring for frost and minimizing spray drift risk
Optional Sensors	Monitor UV conditions: Upgrade to Vantage Pro2 Plus (6327)	Monitor additional canopy conditions: Add Temp/Hum Sensor (6830)	Profile wind for spray conditions: Add extra Anemometer (6410) Manage irrigation: Add Soil Moisture Sensor (6440)

Applications

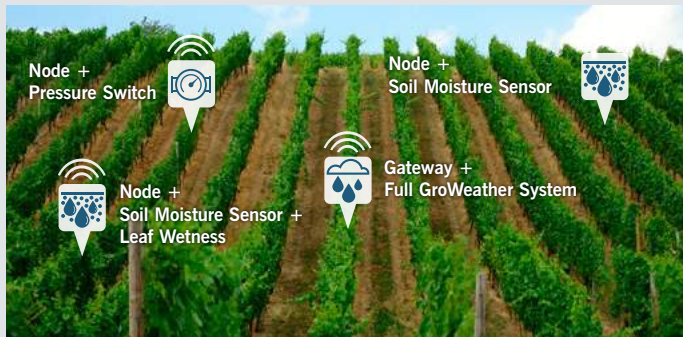

Vineyard

Set up sensors to trigger alerts when frost is a threat. Stay on top of irrigation needs with soil moisture sensors and a pressure switch.

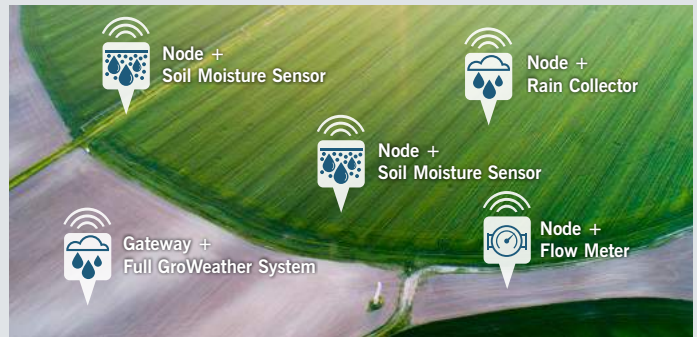

Center Pivot

Irrigation is what matters most. Soil moisture sensors throughout the farm will help determine when and how much to irrigate.

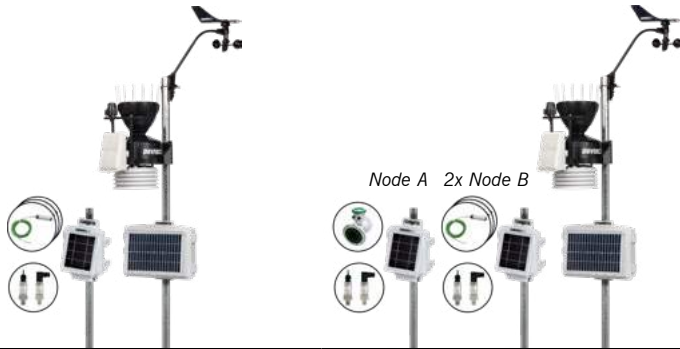

Irrigation System Monitor weather and a single irrigation set	Advanced Irrigation System Monitor weather, pump flow and two irrigation sets
<ul style="list-style-type: none"> • EnviroMonitor Gateway (6801) • EnviroMonitor Node (6810) <ul style="list-style-type: none"> - 3 Soil Moisture Sensors (6440) - Pressure Transducer (third-party) • GroWeather Sensor Suite (6820C) 	<ul style="list-style-type: none"> • EnviroMonitor Gateway (6801) • GroWeather Sensor Suite (6820C) • EnviroMonitor Node A (6810) <ul style="list-style-type: none"> - Flow Meter (third-party) - Pressure Transducer (third-party) • 2x EnviroMonitor Node B (6810) <ul style="list-style-type: none"> - 3 Soil Moisture Sensors (6440) - Pressure Transducer (third-party)
-	-
-	-
Call	Call
Farm Weather Plus <ul style="list-style-type: none"> • Irrigation set monitoring • Control irrigation costs and overuse 	Farm Weather & Irrigation System Plus: <ul style="list-style-type: none"> • Multiple irrigation set monitoring • Monitor pump flow
Monitor additional irrigation sets: Add Node and sensors Monitor multi-level soil moisture: Upgrade to third-party soil moisture profile probe	Monitor additional irrigation sets: Add Node B and sensors Monitor multi-level soil moisture: Upgrade to third-party soil moisture profile probe

Annual Service Plans

The annual fee is calculated for each Gateway and Node activated and billed on a single anniversary date. EnviroMonitor offers three upload interval choices to meet your needs. A Gateway requires a one-time activation fee (#6645).

Contact us directly for annual service plan information and availability for customers outside the US.

Plans for Gateway



Update Interval	Per Gateway Cellular		Per IP Gateway Wi-Fi/Ethernet	
	5 min	Call	6892	Call
15 min	Call	6894	Call	6894D
60 min	Call	6896	Call	6896D

Plans for Node



Update Interval	Per Node Cellular		Per Node Wi-Fi/Ethernet	
	5 min	Call	6882	Call
15 min	Call	6884	Call	6884D
60 min	Call	6886	Call	6886D



Greenhouse and Nursery

Monitor the weather conditions on your site. Measure temperature and humidity inside each greenhouse for a holistic approach to decision-making.



Row Crops

Monitoring soil moisture is crucial for effective and economic irrigation. Add precise current weather data to track growing degree days.

Smart Cities

Create flexible networks of sensors to measure a wide variety of conditions: rain, wind, temperature, humidity, and more. Whether you're installing sensors throughout your yard, across the city, or covering an entire state, Davis has a solution that's right for you.



72°F

High Temperature



6mph

Wind Speed



0.25"

24-HR Rainfall



29.82"

Barometric Pressure

Build a custom network of Davis sensors

Add Sensor Transmitters to your WeatherLink Live, Vantage Connect, Weather Envoy and Vantage Pro2 Console to create a custom network of sensors designed to measure your specific environment.



1,000 ft.

(300 m)
Transmission
Distance



Solar or AC
Powered



9 Month
Battery Backup

6

Supported
Davis Sensors

1

Of Each
Supported Sensor

5

Sensor Ports



Wind Speed
& Direction



Solar
Radiation



Temperature
& Humidity
or



Rainfall



UV



Temperature

Sensor Transmitters

Sensor Transmitters are the building blocks of your custom network of sensors. They can be positioned indoors or outdoors and are capable of transmitting data up to 1,000 ft. (300 m), line-of-sight. Each transmitter can support up to five sensors, including an Anemometer, Rain Collector, Temperature Probe or Temperature & Humidity Sensor, UV Sensor and Solar Radiation Sensor.

Combine Sensor Transmitters with a WeatherLink Live to take full advantage of the devices' capabilities.

See the *ST* symbol on pages 33-34 for compatible sensors and page 41 for transmitter configuration options.

Includes transmitter in weather-resistant housing, mounting hardware, solar panel, and backup battery.

6332 Solar-Powered Wireless Sensor Transmitter

Includes transmitter in weather-resistant housing, mounting hardware, backup battery, and 6.5 ft. (2 m) power adapter cable.

6331 AC Powered Wireless Sensor Transmitter



Wireless Leaf & Soil Moisture/Temperature Station

Robust enough for large-scale agriculture and simple enough for backyard gardening. A fully-populated station can have two Leaf Wetness Sensors, four Soil Moisture Sensors, and four Temperature Probes. Available in two weather-resistant models, without sensors (6345) or with sensors (6345CS). Compatible with 2-Wire Termination Stainless Steel Temperature Probe (6470).

See the *SM* symbol on page 33 for compatible sensors.

Includes transmitter in weather-resistant housing, mounting hardware, solar panel, and backup battery. Add sensors that meet your requirements.

6345 Wireless Leaf & Soil Moisture/Temperature Station (without sensors)

Includes transmitter in weather-resistant housing, mounting hardware, solar panel, backup battery, 4 soil moisture sensors, and 4 temperature probes.

6345CS Complete Wireless Soil Moisture/Temperature Station with 4 Soil Moisture Sensors and 4 Temperature Probes

NIST



1,000 ft.

(300 m)
Transmission
Distance



Solar Powered



9 Month
Battery Backup

4



Soil Moisture
Sensors

4



Temperature
Probes

2



Leaf Wetness
Sensors

Applications

- Pool
- Greenhouse
- Basement/crawl space
- Garage
- And many others



Separate the Vantage Pro2 Anemometer up to 1,000 ft. (300 m) with a Sensor Transmitter.



Use a Wireless Leaf & Soil Moisture/Temperature Station to monitor important growing conditions.



Monitor temperature and humidity where it matters most.

Add another console to any room

Vantage Vue and Wireless Vantage Pro2 Consoles

Add additional Vantage Vue or Vantage Pro2 Consoles to display weather data in the den, bedroom, kitchen—even in your neighbor’s house if it’s within transmission range. Vantage Vue transmitters are radio-compatible with Vantage Pro2 so you can mix and match components. Receive data directly from the outdoor sensors or use your console as a repeater, retransmitting the data from one console to another and extending the transmission range up to another 1,000 ft. (300 m). With Vantage Pro2 only, an additional console can receive data directly from any of our sensor transmitters (see page 31 & 41 for additional details).

6351 Vantage Vue Console/Receiver

6312 Wireless Vantage Pro2 Console/Receiver

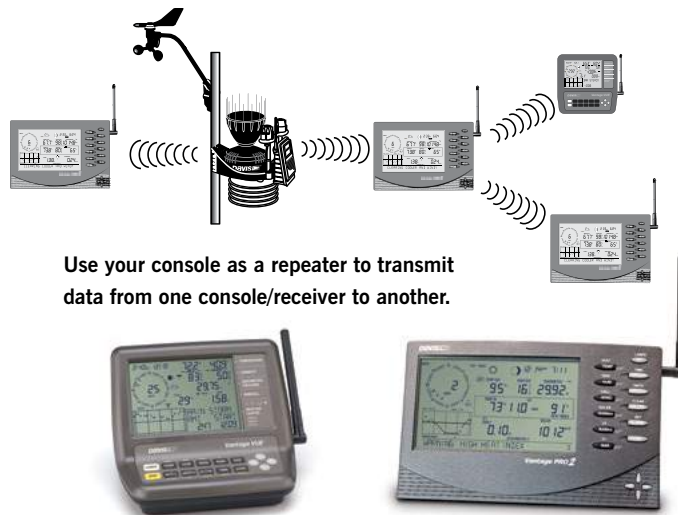

Use your console as a repeater to transmit data from one console/receiver to another.

Extend the range of your wireless station for miles on end

For longer distances or to improve reception in troublesome areas, add one or more Wireless Repeaters. Use repeaters in a daisy chain, retransmitting from a single Vantage Pro2 or Vantage Vue Sensor Suite, or Sensor Transmitter. You can also build a network of repeaters and wireless stations, with some repeaters listening to multiple stations, each with their own unique ID. For use with all Davis wireless transmitters and receivers.

Long-Range Wireless Repeater

In our testing, we achieved an incredible four miles (6,4 km) of transmission distance using two of our long-range repeaters with Yagi antennas. Range varies depending on antenna height, the terrain and foliage, buildings, other man-made structures, and RF interference. Ideal for agricultural or research applications where long distances are an issue. Solar-powered with lithium backup battery (included). Antennas are sold separately.



7654 Long-Range Repeater, Solar-Powered

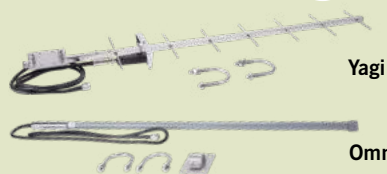

Yagi

Omni

Note: FCC regulations require that US customers select from the antennas above; customers outside the US must purchase third-party antennas in compliance with local regulations.

REPEATER DISTANCES				
Antenna Combination	Multiplier	Maximum Transmission Distance under optimal conditions **		
Dipole – Dipole *	1.00	1,000'	0.2 mile	300 m
Dipole – Omni	1.58	1,580'	0.3 mile	475 m
Dipole – Yagi	3.16	3,160'	0.6 mile	950 m
Omni – Omni	2.50	2,500'	0.5 mile	750 m
Omni – Yagi	5.00	5,000'	1.0 mile	1,500 m
Yagi – Yagi	10.00	10,000'	1.9 miles	3,000 m

* Dipole antennas are found on all Davis wireless weather stations and standard repeaters.

** Typical distance will be less. Outdoors, line-of-sight with minor obstructions or interference, typical distance is about 50 – 80% of the maximum. Through walls or in areas with high RF interference, typical distance may be as low as 20 – 40% of the maximum.

Antennas for Long-Range Repeater

For use with our long-range repeater. Each repeater requires two antennas: one to receive data and another to retransmit it. Omni Antennas transmit or receive in all directions. Yagi Antennas transmit or receive from a single direction but have a longer transmission distance. Mix and match to suit your needs using the table above.

7656 Omni Antenna

7660 Yagi Antenna

Standard Wireless Repeater

Ideal for most applications. Uses the same dipole antenna found on all of our wireless stations. Range is up to 1,000 ft. (300 m) outdoors, line-of-sight. Typical range through walls is 200 ft. to 400 ft. (60 to 120 m). Solar-powered with lithium backup battery (included).



7627 Standard Wireless Repeater, Solar-Powered



Long-Range Antennas for EnviroMonitor

For use with the EnviroMonitor system. Add high gain external antennas to a Gateway and/or Nodes to increase the transmission distance of an EnviroMonitor mesh network up to 10,000 ft. (3,000 m), Node-to-Node and Node-to-Gateway. Antennas include mounting hardware and 4.8 ft. (1,5 m) cable.

7676 EnviroMonitor Long-Range Antenna, 5dBi

7678 EnviroMonitor Long-Range Antenna, 8dBi



Note: FCC regulations require that US customers select from the antennas above; customers outside the US must purchase third-party antennas in compliance with local regulations.

Antenna	ANTENNA RANGES					
	Installation Height					
	6 ft./2 m		8 ft./2,5 m		10 ft./3 m	
Standard Dipole	1,700'	515 m	1,800'	545 m	2,400'	730 m
5dBi External Antenna	2,600'	790 m	4,000'	1,200 m	6,000'	1,800 m
8dBi External Antenna	5,000'	1,500 m	7,000'	2,100 m	10,000'	3,000 m

Sensors

1. Anemometer*

Includes both wind speed and wind direction sensors. Rugged components stand up to hurricane-force winds, yet are sensitive to the lightest breeze. Wind-tunnel tested to speeds of 200 miles per hour (322 km/h). Sealed stainless steel ball bearings for long life. Comes complete with mounting hardware. Includes 40 ft. (12 m) cable.

6410 Anemometer



2. New Sonic Anemometer*

Measures both wind speed and direction using ultrasonic signals calibrated with temperature. Solar-powered with battery backup. Includes mounting hardware, battery, aligning tool, and 40 ft. (12 m) cable.

6415 Sonic Anemometer



3. Turbo Meter™

Reads wind speed in mph, knots, fpm or m/s. Turbine suspended on sapphire jewel bearings responds to the lightest of winds. 3-digit display offers excellent viewing contrast both in bright sunlight and at night. Requires 3 AAA alkaline batteries (not included). 3 oz (85 g) not including batteries.

271 Turbo Meter



4. New AeroCone® Rain Collector with Flat Base (Tipping Spoon)

Shaped for highest accuracy and designed to meet the guidelines of the World Meteorological Organization. Includes exceptionally accurate self-emptying tipping spoon. Measures in 0.01" or 0,2 mm increments. Flat Base makes mounting to flat surfaces easy. Includes mounting hardware and 40 ft. (12 m) cable, bird spikes, and debris screen.

6464 Rain Collector



5. New AeroCone® Rain Collector with Mountable Base (Tipping Spoon)

Uses the Vantage Pro2 base for easy mounting on a pole, post, or flat surface. Meets the guidelines of the World Meteorological Organization. Measures in 0.01" or 0,2 mm increments. Includes mounting hardware and 40 ft. (12 m) cable, bird spikes, and debris screen.

6466 Rain Collector with Mountable Base



6. Leaf Wetness Sensor*

Use to monitor the level of surface moisture on foliage from 0 (completely dry) to 15 (saturated). Add up to two sensors to a single Wireless Leaf & Soil Moisture/Temperature Station. Includes 40 ft. (12 m) cable.

6420 Leaf Wetness Sensor



7. Temperature/Humidity Sensor*

Features both temperature and humidity sensors inside a protective housing. Ideal for indoor use. Includes mounting hardware and 25 ft. (7,6 m) cable.

6834 Temperature/Humidity Sensor



8. Temperature/Humidity Sensor with Radiation Shield*

Features both temperature and humidity sensors inside a radiation shield which protects the sensors from solar radiation and other sources of radiated and reflected heat. Includes 6 plates, hardware for mounting on a fence post or pole, and 25 ft. (7,6 m) cable.

6830 Temperature/Humidity Sensor with Radiation Shield



9. Temperature/Humidity Sensor with 24-Hour Fan-Aspirated Radiation Shield*

Features both temperature and humidity sensors inside the 24-Hour Fan-Aspirated Radiation Shield which protects the sensors from solar radiation and other sources of radiated and reflected heat. This model includes a solar panel to power the motor-driven fan. Includes 10 plates, hardware for mounting on a fence post or pole, and 25 ft. (7,6 m) cable.

6832 Temperature/Humidity Sensor with 24-Hour Fan-Aspirated Radiation Shield



*Sensor comes with RJ Connector. RJ Connector Node Adapter (part #6860) needed when using with EnviroMonitor.



10. Soil Moisture Sensor

Uses electrical-resistance Watermark soil moisture sensor to measure the moisture level of the soil. Does not require periodic maintenance during the growing season. Simply bury at the desired depth to monitor moisture levels throughout the season. Add up to four sensors to a single Leaf & Soil Moisture/Temperature Station. Includes 15 ft. (4,6 m) cable.

6440 Soil Moisture Sensor



11. Stainless Steel Temperature Probe with 2-Wire Termination

Multi-purpose temperature probe with 2.5" (64 mm) long stainless steel housing. Use to measure temperature of air, soil, or water. Add up to four probes to a single Leaf & Soil Moisture/Temperature Station. Includes 15 ft. (4,6 m) direct-burial cable.

6470 Stainless Steel Temperature Probe with 2-Wire Termination



12. Stainless Steel Temperature Probe with RJ Connector*

Multi-purpose temperature probe with 2.5" (64 mm) long stainless steel housing. Use to measure temperature of air, soil, or water. Use with Weather Envoy or Sensor Transmitters. Includes 25 ft. (7,6 m) cable.

6475 Stainless Steel Temperature Probe with RJ Connector



13. Temperature Probe with RJ Connector*

Temperature probe with durable plastic housing. Use to measure temperature of air, soil, or water. Use with Weather Envoy or Sensor Transmitters. Includes 25 ft. (7,6 m) cable.

6477 Temperature Probe with RJ Connector





*Sensor comes with RJ Connector. RJ Connector Node Adapter (part #6860) needed when using with EnviroMonitor.

See pages 10-11 for our line of sensor suites.
See page 42 for extension cables and maximum cable lengths.

14. Solar Radiation Sensor*

Measures the intensity of solar irradiance, enabling display of incident power (Watts per square meter) and cumulative energy (Langleys). Diffuser element and housing are designed specifically for accurate cosine response. Silicon photo diode provides a good match to solar spectrum. Two-piece housing minimizes radiation heating, allows convection cooling of the sensor, and prevents the trapping of water or dust. To mount next to a Rain Collector, use the Sensor Mounting Shelf. Use the Universal Mounting Bracket for other applications. Includes 2 ft. (0,6 m) cable.

6450 Solar Radiation Sensor



15. UV Sensor

Measures the intensity of the sunburning portion of the UV spectrum (UVA and UVB), closely matching the Erythema Action Spectrum. Allows you to display UV index, dose rate, and daily and accumulated dose. Latest technology transducer and newly designed electronics provide greater accuracy and stability. The comb structure provides improved cosine response accuracy

at zenith angles up to 90 degrees. Two-piece housing minimizes radiation heating, allows convective cooling of the sensor, and prevents the trapping of water or dust. To mount next to a Rain Collector, use the Sensor Mounting Shelf. Use the Universal Mounting Bracket for other applications. Includes 2 ft. (0,6 m) cable.

6490 UV Sensor

PATENTED



16. Sensor Mounting Shelf

For mounting Solar Radiation and/or UV Sensors. Rigid shelf with anodized aluminum posts and stainless steel hardware attaches easily next to the rain collector of the Vantage Pro2 Sensor Suite.

6673 Sensor Mounting Shelf

17. Universal Mounting Bracket

For mounting a Solar Radiation Sensor, UV Sensor, or Radiation Shield (7714). Bracket is pre-drilled for easy mounting. Includes mounting hardware.

6670 Universal Mounting Bracket



Accessories



See www.davisinstruments.com/weather/uses to view various ways to use these kits and shelter.

1. Solar Power Kit

Large solar panel powers a wireless console or Weather Envoy inside a weather-resistant shelter. (Outdoor sensors are powered by the solar panel on the sensor suite). Includes a 5-watt solar panel, weather-resistant shelter, regulator circuit, 1.4-amp-hour 6-volt rechargeable battery, mounting hardware, and 10 ft. (3 m) cable.

6614 Solar Power Kit

2. Heavy-Duty Solar Power Kit

Our large solar panel and a 12-amp-hour battery provide enough power for a cabled console and outdoor sensor suite or wireless console where more power is needed. There is enough room inside the weather-resistant shelter to mount a Weather Envoy. When used with a Vantage Vue or Vantage Pro2 Console, mount the console inside a Universal Shelter. Includes 5-watt solar panel, weather-resistant shelter, regulator circuit, 12-amp-hour 6-volt rechargeable battery, mounting hardware, and 10 ft. (3 m) cable.

6612 Heavy Duty Solar Power Kit

3. Extra Solar Panel Kit

Provides additional charging power to the battery in your Solar Power Kit (6612 or 6614), Vantage Connect, or EnviroMonitor Gateway for installations where sunlight is limited. The 5-watt solar panel is mounted on a weather-resistant shelter in which a console or Envoy can be mounted. Includes 5-watt solar panel, weather-resistant shelter, mounting hardware, and a 4 ft. (1,2 m) cable.

6616 Extra Solar Panel Kit



4. Universal Shelter

Protects console and other components located outdoors. Weather-resistant enclosure provides protection from the elements for a Vantage Pro2 console or Vantage Vue console with or without a WeatherLink data logger, an EnviroMonitor IP Gateway, or for a Weather Envoy with WeatherLink data logger. Includes mounting hardware. Measures 13.75" x 10" x 4.18" (34,9 cm x 25,4 cm x 10,6 cm).

6618 Universal Shelter





5. Shelter Angle Bracket

Changes the EnviroMonitor Gateway, Vantage Connect, or Universal Shelter solar panel's angle from 5 degrees to 30 degrees to increase efficiency at lower latitudes. Includes mounting hardware.

6671 Shelter Angle Bracket



6. AC Charger Kits

Charges the battery in a Vantage Connect or EnviroMonitor Gateway/Node where sunlight is too low to use solar. Includes 5.5 ft. (1,6 m) cable.

6710 AC Charger Kit for Cellular EnviroMonitor Gateway & Vantage Connect



NEW 6714 AC Power Kit for EnviroMonitor Node



7. Rain Collector Heater

For older sensor suites that do not have the AeroCone. Heater and insulation fit neatly inside the old style rain collector. For use in cold climates to measure freezing rain or the moisture content of snowfall. Requires access to AC power; cannot be run using a solar power kit. Includes 24-watt, 24-volt heater with thermal cut-off switch, control unit, insulating reflective blanket, AC adapter, and 50 ft. (15 m) cable.

7720 Rain Collector Heater

7 & 7a. Rain Collector and Heater

For sensor suites with an AeroCone. Temporarily replace your rain cone with a straight-sided rain cone in order to use the heater. In addition to components listed above (in 7), this product includes the rain collector, debris screen, and bird spikes.

7721 Rain Collector and Heater

8. 3-volt Lithium Battery CR123

Replacement 3-volt lithium battery (CR123).

8415 3-volt Lithium Battery CR123



9. 6-volt 12Ah Battery

Replacement 6-volt 12Ah battery for Vantage Connect or EnviroMonitor Gateway.

6712 6-volt 12Ah Battery



10. RJ Connector Node Adapter

Connect sensors with RJ connectors to your EnviroMonitor Node with this adapter.

6860 RJ Connector Node Adapter



11. Radiation Shield

Received a 5-star rating from the World Meteorological Organization. Protects temperature sensors from solar radiation and radiated or reflected heat sources. Multi-plate construction for maximum airflow. Use with Leaf & Soil Moisture/Temperature Station and all temperature sensors. Or, install your own sensor in the sensor chamber. Sensor chamber: 4.25" x 2.5" (107,9 mm x 63,5 mm). Includes 8 plates, mounting bracket, and mounting hardware.

7714 Radiation Shield Assembly required.

12. Daytime Fan-Aspirated Radiation Shield Kit

An economical way to add the benefits of fan aspiration by retrofitting your Vantage Pro2 or Pro2 Plus. Less costly than our 24-Hour Fan-Aspirated Radiation Shield, but nearly 75% as effective in reducing the effects of daytime radiation. With no backup battery, the fan only runs during daylight hours and will cease running at night when solar radiation effects are reduced. Includes fan, solar panel, additional radiation shield plates, and hardware.

7747 Daytime Fan-Aspirated Radiation Shield Kit



13. 24-Hour Fan-Aspirated Radiation Shield

Our 24-Hour Fan-Aspirated Radiation Shield helps maximize accuracy of sensor readings. A motor-driven fan draws a constant airflow through the sensor chamber at 500 feet per minute (2,5 m/s). At night, when the effects of radiation are less, this solar-powered model runs on battery power and the airflow slows to 280 feet per minute (1,4 m/s). Install your own sensor in the sensor chamber. Sensor chamber: 2.24" x 3" (56,8 mm x 76,2 mm). Includes 10 plates, rechargeable batteries, mounting hardware, and 25 ft. (7,6 m) cable.

6838 24-Hour Fan-Aspirated Radiation Shield

14. Replacement Motor Kit without Batteries

Replacement motor for the Daytime Fan-Aspirated Radiation Shield. We recommend replacing every two years.

7758 Replacement Motor

15. Replacement Motor Kit with Batteries

Replacement motor for the 24-Hour Fan-Aspirated Radiation Shield. Includes two rechargeable C-batteries. We recommend replacing every two years.

7758B Replacement Motor and Replacement Batteries

16. USB Power Cord

Powers the Vantage Vue Console, Vantage Pro2 Console, WeatherLink Live or the Weather Envoy. Includes 6.5 ft. (2 m) cable.

6627 USB Power Cord

Accuracy You Can Rely On

We subject our products to harsh environmental testing. Every station goes through a minimum of 10 tests before shipping. If it's a Davis, it's accurate and reliable.



Vantage Console Features

- Vantage Pro2 and Vantage Vue
- Vantage Pro2 only
- Vantage Vue only

	BAR	HUMIDITY			RAIN			TEMPERATURE				WIND			WITH OPTIONAL SENSORS								
	Barometric Pressure	Inside Humidity	Outside Humidity	Dew Point	Rainfall Amount	Rain Storm Amount	Rain Rate	Inside Temperature	Outside Temperature	Heat Index	Wind Chill	Wind Speed	Wind Direction	Direction of High Speed	Evapotranspiration	Humidity (Extra)	Leaf Wetness	Soil Moisture	Solar Radiation	Temperature (Extra)	Temp-Hum-Sun-Wind	UV Radiation	UV MEDs
Update Interval*	1 min	1 min	50 sec	10 sec	20 sec	20 sec	20 sec	1 min	10 sec	10 sec	10 sec	2.5 sec	2.5 sec	2.5 sec	1 hour	50 sec	1 min	80 sec	50 sec	10 sec	10 sec	50 sec	50 sec
CONSOLE DISPLAYS																							
Reading at end of update interval	●	●	●	●				●	●	●	●		●			●	●	●	●	●	●	●	●
Total amount for the interval					●	●									●								●
Average reading for the interval												●											
High reading for the interval							●																
SET ALARMS for																							
Special Alarms	1				2	3						4			5								6
High Reading		●	●	●			●	●	●	●		●			●	●	●	●	●	●	●	●	●
Low Reading		●	●	●				●	●		●				●	●	●		●				
DISPLAYED but not graphed																							
Current Year High	●	●	●	●				●		●		●		●	●	●	●		●				
Current Year Low	●	●	●	●				●			●				●	●	●		●				
GRAPHED & DISPLAYED for last 24 hrs of each of the following (25 hrs for Vantage Vue)																							
EOP	End-of-15-Minute Period Readings	●																					
	End-of-Hour Period Readings	●	●	●	●			●	●	●						●	●				●		
TOTALS	15-minute Period Totals				●																		
	Hourly Totals				●										●								●
	Daily Totals				●										●								●
	Monthly Totals				●										●								
	Storm Totals (with start & end date)					●																	
	Yearly Totals				●										●								
AVERAGES	10-Minute Averages (2 min. for VV)											●											
	Hourly Averages or Dominant											●	●					●				●	
	Daily Averages or Dominant											●	●					●					
	Monthly Averages or Dominant											●	●					●					
	Yearly Averages											●			●								
HIGHS	One-Minute Highs					●																	
	Hourly Highs					●						●											
	Daily Highs	●	●	●	●			●	●	●	●	●				●	●	●		●	●	●	●
	Monthly Highs	●	●	●	●			●	●	●	●	●				●	●	●		●	●	●	●
	Yearly Highs					●				●		●											
LOWS	Hourly Lows										●												
	Daily Lows	●	●	●	●			●	●	●	●				●	●							
	Monthly Lows	●	●	●	●			●	●	●	●				●								
	Yearly Low										●												

*Update interval may vary depending on station ID and type of station.

SPECIAL ALARMS

- 1 **Storm Warning:** Amount of barometric pressure fall.
- 2 **Storm Clearing:** Amount of barometric pressure rise.
- 3 **Flash Flood Warning:** 15-minute rainfall amount.
- 4 **24-hour Rain Alarm:** 24-hour rainfall amount.
- 5 **Rainstorm Alarm:** Rainfall amount for current storm.
- 4 **High Wind Speed and 10-Minute Average Wind Speed Alarms**
- 5 **Daily Evapotranspiration Amount Alarm**
- 6 **Daily UV Dose Alarm**

NIST NIST-Traceable Sensors

In the USA, the National Institute of Standards & Technology (NIST) develops and maintains the standards of measurement to which all others are ultimately traced. Numerous calibrations, tests, and measurement assurance programs are delivered directly to approximately 10,000 companies. From these companies, NIST-traceable intermediate service providers are the next link in a network that joins together the makers and users of precision instruments.

Davis Instruments is proud to provide this calibration service in our California factory utilizing NIST-traceable references for those customers who require it. For users who require this additional service, calibration of new and previously owned sensors is available. For the cost of individual sensors, please contact us for pricing.



Anemometers are wind-tunnel tested in our California factory.

Function		Vantage Vue	Vantage Pro2	USA Units			Metric Units		
				RESOLUTION	RANGE	ACCURACY ±	RESOLUTION*	RANGE	ACCURACY ±
AGRICULTURAL	Evapotranspiration		●	0.01"	0 to 199.99"	5%	0,1 mm	0 to 1999,9 mm	5%
	Growing Degree-Days		○	0.1 Degree-Day	Unlimited	0.5 Degree-Day	0,1 Degree-Day	Unlimited	0,3 Degree-Day
	Cooling/Heating Degree-Days	✓	○	0.1 Degree-Day	Unlimited	0.5 Degree-Day	0,1 Degree-Day	Unlimited	0,3 Degree-Day
	Leaf Wetness		●	1	0 to 15	0.5	1	0 to 15	0.5
	Soil Moisture		●	1 cb	0 to 200 cb		1 cb	0 to 200 cb	
BAROMETRIC PRESSURE	Barometric Pressure (Elevation range: -999' to +15,000'; -600 to +4570 m)	✓	✓	0.01" Hg	16" to 32.5" Hg	0.03" Hg	0,1 mm Hg 0,1 mb or hPa	410 to 820 mm Hg 540 to 1100 mb or hPa	0,8 mm Hg 1,0 mb or hPa
	Three-Hour Trend	✓	✓	Slow ≥ 0.02" Hg Rapid ≥ 0.06" Hg	5-Position Arrow		Slow ≥ 0,5 mm (0,7 mb) Rapid ≥ 1,5 mm (2 mb)	5-Position Arrow	
HUMIDITY	Inside Humidity	✓	✓	1%	1% to 100%	2%	1%	1% to 100%	2%
	Outside Humidity Sensor Suite	✓	✓	1%	1% to 100%	2%	1%	1% to 100%	2%
	Outside Humidity (T/H Sensors)		●	1%	1% to 100%	2%	1%	1% to 100%	2%
	Outside Humidity (VP2 T/H Stations)		●	1%	1% to 100%	2%	1%	1% to 100%	2%
	Inside Dew Point	○	○	0.1°F	-60° to +140°F	2°F	0,1°C	-50° to +60°C	1°C
	Outside Dew Point Vue	✓		1°F	-105° to +130°F	2°F	1°C	-76° to +54°C	1°C
	Outside Dew Point VP2 Sensor Suite		✓	1°F	-105° to +130°F	2°F	1°C	-76° to +54°C	1°C
RAINFALL	Rainfall		✓	0.01"	0 to 199.99"	3% 4%	0,2 mm	0 to 6553 mm	3% 4%
	Rate of Rainfall	✓	✓	0.01"/hr	0 to 30"/hr	5% ≤ 10"/hr	0,1 mm/hr	0 to 762 mm/hr	5% ≤ 254 mm/hr
SOLAR & UV	Solar Radiation		●	1 W/m2	0 to 1800 W/m2	5%	1 W/m2	0 to 1800 W/m2	5%
	Solar Energy		○	0.1 Ly	1999.9 Ly	5%	0,1 Ly	1999,9 Ly	5%
	UV Dose		●	0.1 MEDs	0 to 199 MEDs	5%	0,1 MEDs	0 to 199 MEDs	5%
	UV Index		●	0.1	0 to 16	5%	0,1	0 to 16	5%
TEMPERATURE	Inside Temperature	✓	✓	0.1°F	+32° to +140°F	0.5°F	0,1°C	0° to +60°C	0,3°C
	Outside Temperature Sensor Suite	✓	✓	0.1°F	-40° to +150°F	0.5°F	0,1°C	-40° to +65°C	0,3°C
	Outside Temp (Extra Temp Sensor)		✓	1°F	-40° to +150°F	1°F	1°C	-40° to +65°C	1°C
	Outside Temp (Extra Temp Probe)		●	1°F	-50° to +150°F	1°F	1°C	-45° to +65°C	1°C
	Soil or Water Temp (Temp Station)		●	1°F	-40° to +150°F	1°F	1°C	-40° to +65°C	1°C
	Inside Heat Index	○	○	0.1°F	+32° to +999°F	2°F	0,1°C	0° to +537°C	1°C
	Outside Heat Index Vue	✓		1°F	-40° to +165°F	2°F	1°C	-40° to +74°C	1°C
	Outside Heat Index VP2 Sensor Suite		✓	1°F	-40° to +165°F	2°F	1°C	-40° to +74°C	1°C
	Temp/Hum/Wind Index Vue	○		0.1°F	-110° to +165°F	3°F	0,1°C	-79° to +74°C	1,5°C
	Temp/Hum/Wind Index VP2 Sensor Suite		○	1°F	-110° to +165°F	2°F	1°C	-79° to +74°C	1°C
	Temp/Hum/Solar/Wind Index VP2 Sensor Suite		●	1°F	-90° to +165°F	4°F	1°C	-68° to +74°C	2°C
	Wind Chill Vue	✓		1°F	-110° to +135°F	2°F	1°C	-79° to +57°C	1°C
	Wind Chill Sensor Suite on VP2		✓	1°F	-110° to +135°F	2°F	1°C	-79° to +57°C	1°C
	Wet-bulb			1°F	-40° to +150°F	2°F	1°C	-40° to +65°C	1°C
TIME/DATE	Time	✓	✓	1 minute	12/24 hours	8 sec/mo	1 minute	12/24 hours	8 sec/mo
	Date	✓	✓	month/day	Leap Year	8 sec/mo	day/month	Leap Year	8 sec/mo
	Sunrise & Sunset	✓	✓	1 minute	12 hours	1 minute	1 minute	24 hours	1 minute
WIND	Wind Direction	✓	✓	1°	0° to 360°	3°	1°	0° to 360°	3°
	Compass Rose	✓	✓	22.5°	16 compass points		22,5°	16 compass points	
	Wind Speed (Standard Anemometer)	✓	✓	1 mph 1 knot	1 to 200 mph 1 to 174 knots	5%	0,1 m/s 1 km/hr	1 to 80 m/s 1 to 320 km/hr	5%
	Wind Speed (Sonic Anemometer)		●	1 mph 1 knot	0 to 89 mph 0 to 78 knots	4%	0,1 m/s 1 km/hr	0 to 40 m/s 0 to 144 km/hr	4%
	Direction of High Speed	✓	✓	22.5°	16 compass points		22,5°	16 compass points	
	Wind Run	○	○	0.01 miles 0.01 nautical miles	Unlimited	5%	0,01 kilometers	Unlimited	5%

Except for rainfall, all variables are measured in US units of measure and rounded to the nearest metric unit shown in the Resolution column.

- ✓ Included
- Optional sensor required, but shown on console
- Optional and requires WeatherLink.
- Solar Energy requires Solar Radiation sensor.

*Resolution refers to the number of digits or decimal places displayed on the console. For metric units, this is not the actual unit of measure except for rainfall. Our rain collector measures in true 0.01" or 0,2 mm increments. All other weather variables are measured and accumulated in US units of measure, which are then converted to metric units for display purposes.

For complete specifications, visit www.davisinstruments.com/resources/weather-monitoring/#support then click on Specification Sheets.

Which sensors can you use with your transmitter?

See pages 41 for the maximum number of transmitters that can report to a single Vantage Pro2/Vue console, WeatherLink Live, Weather Envoy or Vantage Connect.

- Included
- Optional
- 4 Maximum sensors for that transmitter

		Product No.	WIRELESS TRANSMITTERS														
			6250 Vantage Vue 6357 Vantage Vue Sensor Suite	6152 Vantage Pro2 6322 Vantage Pro2 Sensor Suite	6153 Vantage Pro2 with Fan-Aspirated Rad Shield 6323 Vantage Pro2 Sensor Suite with Fan-Aspirated Rad Shield	6162 Vantage Pro2 Plus 6327 Vantage Pro2 Plus Sensor Suite	6163 Vantage Pro2 Plus with Fan-Aspirated Rad Shield 6328 Vantage Pro2 Plus Sensor Suite with Fan-Aspirated Rad Shield	6820 GroWeather Sensor Suite with Solar Radiation Sensor and Passive Radiation Shield	6345 Leaf Wetness & Soil Moisture/Temp Station w/o sensors	6345CS Complete Soil Moisture/Temp Station	6332 Solar-Powered Wireless Sensor Transmitter	6331 AC Powered Wireless Sensor Transmitter	6810 EnviroMonitor Node				
Sensor Options and Accessories	Integrated Rain Collector	--	●	●	●	●	●	●									
	Rain Collector	7852											●	●	●		
	Integrated Anemometer	--	●														
	Detachable Anemometer	6410		●	●	●	●	●	●				●	●	●		
	Sonic Anemometer	6415		●	●	●	●	●	●				●	●	●		
	Integrated Temperature/Humidity	--	●	●	●	●	●	●	●								
	Stainless Steel Temperature Probe with 2-Wire Termination	6470									4	4					●
	Temperature Probe with RJ Connector*	6477												●	●	●	
	Stainless Steel Temperature Probe with RJ Connector*	6475												●	●	●	
	Temperature/Humidity Sensor with Radiation Shield	6830												●	●	●	
	Temperature/Humidity Sensor with 24-Hour Fan-Aspirated Radiation Shield	6832												●	●	●	
	Temperature/Humidity Sensor	6834												●	●	●	
	Passive Radiation Shield	7714	●	●		●			●	●	●	●	●	●	●	●	
	Daytime Fan-Aspirated Radiation Shield	7747		●		●			●								
	24-Hour Fan-Aspirated Radiation Shield	--			●				●								
	Solar Radiation Sensor	6450			●	●	●	●	●					●	●	●	
	UV Radiation Sensor	6490			●	●	●	●	●					●	●		
	Sensor Mounting Shelf for UV/Solar	6673			●	●	●	●	●								●
Leaf Wetness Sensor	6420									2	2					●	
Soil Moisture Sensor	6440									4	4					●	
Third-party sensors	--															●	

*Can also be used with Weather Envoy and Vantage Connect to replace the internal temperature sensor.

Current Draw & Battery Life*	Current Draw in Milliamperes			Estimated Backup Battery Life in Days*	
	Lights Off	Lights On	With Data Logger (USB/SER†)	Without Data Logger	With Data Logger (USB/SER†)
Vantage Vue Console/Receiver	1	160	1	9 months	9 months
Vantage Pro2	Wireless	1	160	1	9 months
	Cabled	10	170	10	27 days
Weather Envoy	Wireless	1	N/A	1	N/A
	Cabled	10	N/A	10	10 days
WeatherLink Live	Wireless	100		Up to 6 days	

*Information based on premium alkaline batteries. Actual battery life will vary depending on station setup and usage. N/A = not applicable.

†6510USB USB Data Logger, 6510SER Serial Data Logger



Which transmitters can you use with your receiver?

See pages 41 for the maximum number of transmitters that can report to a single Vantage Pro2/Vue Console, WeatherLink Live, Weather Envoy or Vantage Connect.

- Included
- Optional
- Included but additional can be added

		SYSTEMS & RECEIVERS																
		WIRELESS								CABLED								
		6250 Vantage Vue	6152 Vantage Pro2	6153 Vantage Pro2 with Fan-Aspirated Rad Shield	6162 Vantage Pro2 Plus	6163 Vantage Pro2 Plus with Fan-Aspirated Rad Shield	6316 Wireless Weather Envoy	6622 Vantage Connect	6351 Vantage Vue Console only	6312 Vantage Pro2 Console only	6152C Vantage Pro2	6162C Vantage Pro2 Plus	6316C Cabled Weather Envoy	6622C Cabled Vantage Connect				
Wireless Options	Vantage Vue Console	6351	●	●	●	●	●	●	●	●	●	●						
	Vantage Vue Sensor Suite	6357	●						●	●	●	●						
	Wireless Vantage Pro2 Console	6312	●	●	●	●	●	●	●	●	●	●						
	Wireless Vantage Pro2 Sensor Suite	6322		●					●	●	●	●						
	Wireless Vantage Pro2 Sensor Suite with 24-Hour Radiation Shield	6323			●				●	●	●	●						
	Wireless Vantage Pro2 Sensor Suite with UV-Solar	6327				●			●	●	●	●						
	Wireless Vantage Pro2 Sensor Suite with 24-Hour Radiation Shield & UV Solar	6328					●		●	●	●	●						
	Wireless GroWeather Sensor Suite with Solar Radiation Sensor	6820							●	●	●	●						
	Wireless WeatherLink Live	6100	●	●	●	●	●	●	●	●	●	●						
	Wireless Weather Envoy	6316	●	●	●	●	●	●	●	●	●	●						
	Wireless Leaf & Soil Moisture/Temperature Stations	6345		●	●	●	●	●	●	●	●	●						
	Complete Soil Moisture/Temperature Station	6345CS		●	●	●	●	●	●	●	●	●						
	Solar-Powered Wireless Sensor Transmitter	6332		●	●	●	●	●	●	●	●	●						
	AC Powered Wireless Sensor Transmitter	6331		●	●	●	●	●	●	●	●	●						
	Standard Wireless Repeater, AC-Powered	7626	●	●	●	●	●	●	●	●	●	●						
	Standard Wireless Repeater, Solar-powered	7627	●	●	●	●	●	●	●	●	●	●						
	Long-Range Wireless Repeater, Solar-Powered	7654	●	●	●	●	●	●	●	●	●	●						
	Solar Power Kit for Wireless (includes 1.4 amp hour 6-volt battery)	6614	●	●	●	●	●	●	●	●	●	●						
Cabled Options	Cabled Vantage Pro2 Console	6312C										●	●					
	Cabled Weather Envoy	6316C												●				
	Cabled Vantage Pro2 Sensor Suite	6322C										●		●	●			
	Cabled Vantage Pro2 Sensor Suite with UV & Solar	6327C										●	●	●	●			
	Cabled GroWeather Sensor Suite with Solar Radiation Sensor	6820C												●	●			
	Heavy Duty Solar Power Kit (includes 12 amp hour 6-volt battery) *	6612	●	●	●	●	●	●	●	●	●	●	●	●	●	●	●	●
Installation Options	Rain Collector Heater (compatible with straight-sided rain cone)	7720		●	●	●	●					●	●					
	Mounting Tripod	7716	●	●	●	●	●		●			●	●			●		
	Mounting Pole Kit	7717	●	●	●	●	●		●			●	●			●		
	Extra Solar Panel Kit **	6616							●							●		
	Universal Shelter	6618	●	●	●	●	●	●		●	●	●	●	●	●	●	●	
	Daytime Fan-Aspirated Radiation Shield	7747		●		●						●	●					
	Sensor Mounting Shelf	6673		●	●	●	●					●						

* Can also be used on wireless stations when more power is needed. ** Can be paired with 6612 and 6614.

WIRELESS VANTAGE PRO2

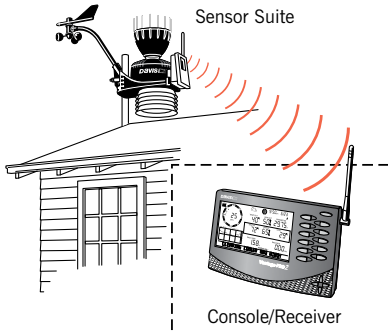

REMOTE ANEMOMETER (CABLED SYSTEM)

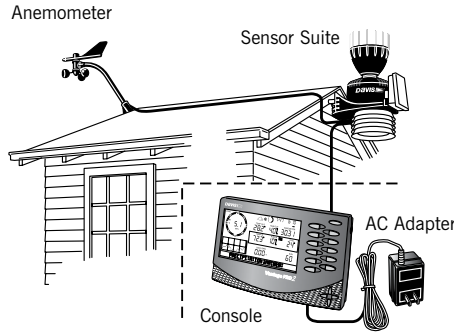

SENSOR TRANSMITTER

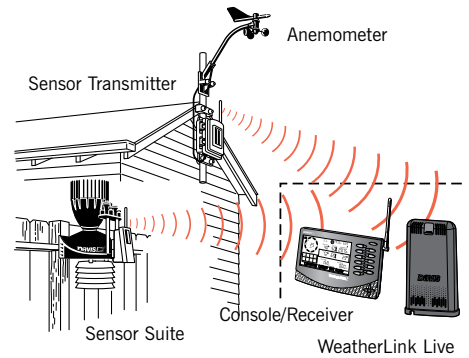

STATION SHOWING SOLAR POWER KIT & SOIL MOISTURE SENSORS

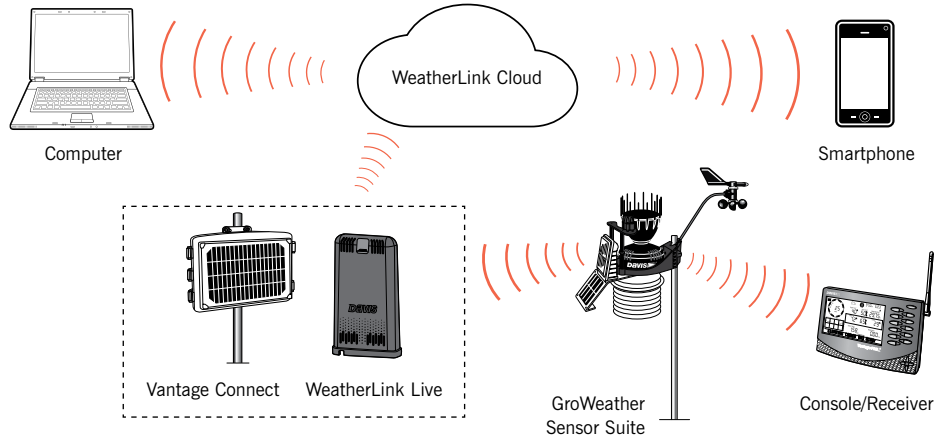
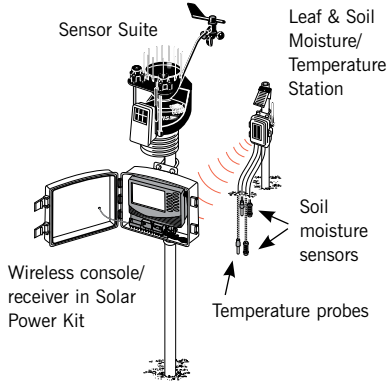

WHICH SENSORS CAN YOU USE WITH YOUR CONSOLE/RECEIVER

Sensor Type	WeatherLink Live		Vantage Pro2		Vantage Vue		Weather Envoy	Vantage Connect	EnviroMonitor
	Receiver		Console		Console		Receiver	Receiver	Receiver
	Shown	Logged	Shown	Logged	Shown	Logged	Logged	Logged	Logged
Anemometer	8	8	1	1	1 *	1 *	1	1	80+
Temperature Probe	32	32	8	4	1 *	1 *	3	3	80+
Temperature/Humidity	8	8	8	4/3	1/1 *	1/1 *	4/3	4/3	80+
Rain	8	8	1	1	1 *	1 *	1	1	80+
UV	8	8	1	1	0	0	1	1	80+
Solar Radiation	8	8	1	1	0	0	1	1	80+
Leaf Wetness	16	16	2	2	0	0	2	2	80+
Soil Moisture	32	32	4	4	0	0	4	4	80+
Third-Party Sensors	0	0	0	0	0	0	0	0	80+ **

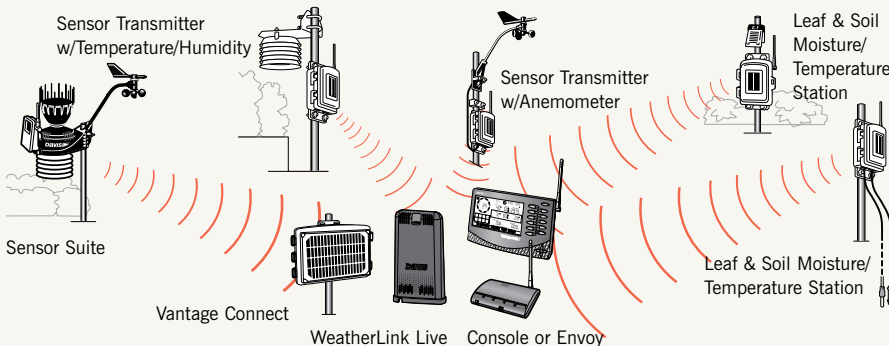

"Shown" = Current conditions seen on the LCD display or WeatherLink

"Logged" = Stored historical archive records on the WeatherLink Cloud

* One Sensor Suite or transmitter only.

** See page 24 or go to www.davisinstruments.com/em-sensors for supported sensors.

Each WeatherLink Live, Vantage Pro2, Weather Envoy and Vantage Connect console can receive data from up to eight different transmitting stations.

Cabled Weather Envoy

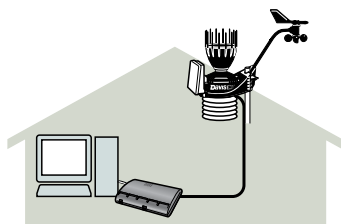
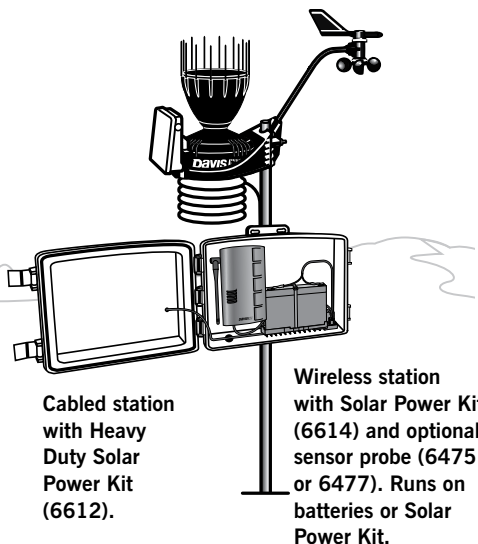

Can be used with one cabled Sensor Suite

Wireless Weather Envoy

Can listen to up to eight transmitting stations

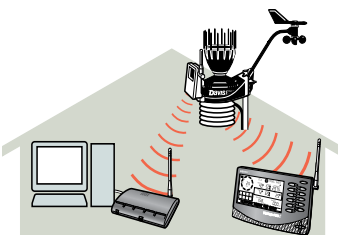
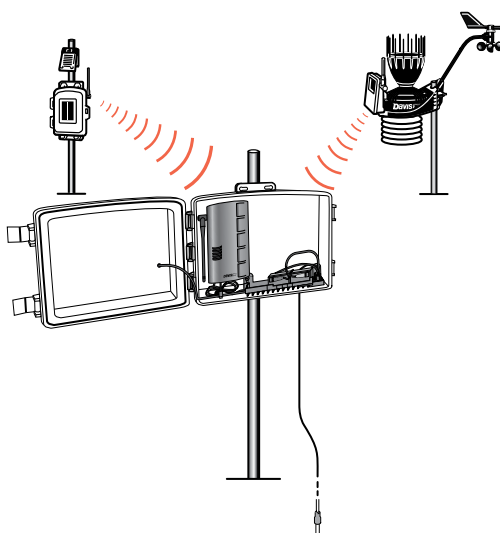

Transmit to both the Weather Envoy and console

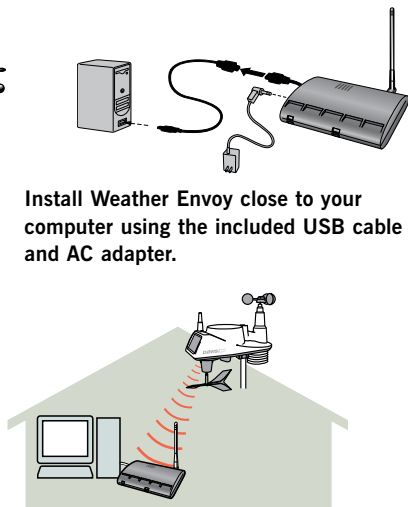

Install Weather Envoy close to your computer using the included USB cable and AC adapter.

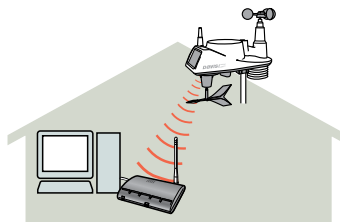

Use Weather Envoy in place of Vantage Vue or Vantage Pro2 Console.



Retransmit data to Weather Envoy from console

EXTENSION CABLES

Our Standard 4-Conductor Extension Cables include a coupler kit (protective shell; cable coupler; and five waterproof, silicone-filled, crimp-style splice connectors) for joining two cables together, indoors or out. Use the chart below to determine maximum cable lengths.

Product	Included Cable Length	Maximum Cable Length
Wireless Vantage Pro2	40' (12 m)	240' (73 m)*
Cabled Vantage Pro2	40' (12 m) 100' (30 m)	240' (73 m)* 1000' (300 m)
Cabled Vantage Pro2 Sensor Suite with Cabled Vantage Connect	100' (30 m)	1000' (300 m)
WeatherLink for Vantage Pro2 and Vantage Vue (serial port versions)**	8' (2,4 m)	48' (14,6 m)
Solar Radiation Sensor (6450)	2' (0,6 m)	125' (38 m)
UV Sensor (6490)	2' (0,6 m)	125' (38 m)
Stainless Steel Temperature Probe with RJ Connector (6475)	25' (7,6 m)	200' (61 m)
Temperature Probe with RJ Connector (6477)		
Leaf Wetness Sensor (6420)	40' (12 m)	200' (61 m)
Anemometer (6410) & Sonic Anemometer (6415)	40' (12 m)	240' (73 m)*
Rain Collector (standalone, 7852)	40' (12 m)	900' (270 m)
Rain Collector with Mountable Base (7857)	40' (12 m)	900' (270 m)
Temperature/Humidity Sensor (6830) (6832)	25' (7,6 m)	25' (7,6 m)

* **Anemometer (6410) Cables:** Maximum displayable wind speed decreases as the length of cable increases. At 140' (42 m) of cable, the maximum wind speed displayed is 135 mph (60 m/s). At 240' (73 m) of cable, the maximum wind speed displayed is 100 mph (45 m/s).

** **WeatherLink USB:** Extension cables may be purchased from a computer supplier.

To extend the cables on the Temperature Probe (6470), Soil Moisture Sensor (6440), and Rain Collector Heater (7720), please call us directly.

Things to consider when purchasing a weather station

What weather variables are measured and recorded?

Most other stations offer barometric pressure, outside humidity and dew point, daily and yearly rainfall, wind speed and direction, wind chill and outside temperature. Some also offer inside temperature and humidity, and a few even give you extra outside temperatures and rain rate. Only Vantage Pro2 or Vantage Vue give you those features, plus:

- Additional Rainfall Information: 15-minute, hourly, monthly and yearly rainfall, rainfall amounts, and dates for each of the last 24 storms.
- Additional Wind Speed Information: 10-minute average wind speed and dominant wind direction. In addition, with Vantage Vue, you get 2-minute average speed, high speed and direction in the last ten minutes.
- Apparent Temperature: Heat index, and with Vantage Pro2's optional solar radiation sensor, the temperature-humidity-sun-wind index.
- Vantage Pro2 optional Solar and UV Radiation Sensors: Greater awareness of the dangers of excessive exposure to the sun.
- For agricultural users: Evapotranspiration, leaf wetness, soil moisture and soil temperature with Vantage Pro2 optional sensors.

How often is the data updated?

Davis Sensor Suites transmit a data packet every 2.5 seconds. Highly variable conditions like wind speed and direction are updated with every packet, while less variable conditions are updated every 10 to 50 seconds.

How accurate is the data?

Davis stations generally beat their similarly-priced competition in accuracy, resolution, and range. We proudly post our specs on our website.

How do you access the data?

Davis stations let you access, analyze, and store your data on the console, your computer, the internet, or on your smartphone.

• On the console

You'll see much more than just current conditions on your console. You'll get highs and lows (and/or totals or averages) for just about all weather conditions, with time and date, for the last 24 (Vantage Pro2) or 25 (Vantage Vue) days, months, or years. You'll see the data numerically and you can graph just about every weather variable, with averages and highs and lows for most, and go back in time for minutes, days, months and years. With the graphs and the Weather Center on Vantage Vue, you can do tons of analysis right there on your console.

• On your computer, the WeatherLink Cloud or your smartphone

With the Davis WeatherLink family, and one of our choices of data-collection devices, you can choose to upload your data to the WeatherLink Cloud. You can access and analyze it 24/7 on WeatherLink.com or your smartphone with the WeatherLink Mobile app.

How durable is the station?

There are many, many thousands of Davis stations out in the elements all over the world. Davis stations have endured ice storms and hurricanes. They have transmitted data for years through snow, rain, and ice. They are installed in deserts and at the seashore. They are built to function at high elevations up to 15,000 feet (4570 meters), and to remain robust no matter what conditions they are subjected to. We warranty our stations and offer repair services. We are very proud to say that you can expect your station to provide you with weather data for many years.

How long has the company been in business?

Established in 1963, Davis Instruments opened up the personal weather station market in 1989. Our weather stations are assembled and tested right here in Hayward, California, where we have a full staff giving the best customer service and support in the business.

Limited Warranty

We warrant our products to be free of defects in material and workmanship for one year from date of original purchase. While we make every effort to carefully manufacture our products to the highest standards of quality, occasionally parts may be found to be missing, defective or damaged. If you have a defective part, return the product to us, shipping charges prepaid. Include proof of purchase and a written explanation of the trouble. During the warranty period, we will, at our option, either repair or replace the product free of charge. This warranty does not cover damage due to improper installation or use, lightning, negligence, accident or unauthorized service, or to incidental or consequential damages beyond the Davis products themselves. Implied warranties are limited in duration to the life of this limited warranty. Some states do not allow limitations on how long an implied warranty lasts, or the exclusion or limitation of incidental and consequential damages, so the above limitation may not apply to you. This warranty gives you specific legal rights. You may have other rights, which vary from state to state or country to country.

Details, specifications, and prices are subject to change at any time without notice.

30-Day Money-Back Guarantee

If for any reason you are unsatisfied with anything purchased from us, return it within 30 days and we will gladly refund your purchase price. Shipping charges are not refundable.

The contents of this catalog are the sole property of Davis Instruments and cannot be copied, reproduced or reused without written consent from Davis Instruments. Davis, Davis Instruments, the Davis logo, AeroCone, EnviroMonitor, GroWeather, Vantage Connect, Vantage Pro, Vantage Vue, WeatherLink are registered trademarks of Davis Instruments. Weather Envoy and Turbo Meter are trademarks of Davis Instruments.

Windows®, Mac®, Watermark®, Amazon®, Alexa®, iOS®, App Store®, Google Play®, and Android™ are trademarks of their respective companies.

Davis Instruments Quality Management System is ISO 9001 certified.

©2020 Davis Instruments Corp. All rights reserved.



Photo credit for front cover:

Mike Olbinski is a storm chaser and a photographer, and he loves being able to mesh the two passions to capture some amazing scenes out there, from tornadoes and supercells, to lightning, dust storms and amazing sunsets. Oh, and he loves his Vantage Vue!





www.gallery.mikeolbinski.com/finestart

[f mikeolbinskiphotography](https://www.facebook.com/mikeolbinskiphotography)



3465 DIABLO AVENUE
HAYWARD, CA 94545-2778

WWW.DAVISINSTRUMENTS.COM
ISO 9001 CERTIFIED COMPANY

-  Davis.Instruments
-  @davisinst
-  davisinstruments
-  davisinstruments
-  davisinstruments

GENERAL

Phone: +1 510 732 9229
E-mail: info@davisinstruments.com

CUSTOMER SERVICE ORDER LINE

Phone: +1 510 732 9229
Fax: +1 510 670 0589
E-mail: sales@davisinstruments.com

TECHNICAL QUESTIONS/ TROUBLESHOOTING

Phone: +1 510 732 7814
Fax: +1 510 670 0589
E-mail: support@davisinstruments.com

ENVIROMONITOR[®]

DAVIS

Make Every Acre Count

EnviroMonitor is a simple system that allows you to measure and manage key elements you need to keep crops healthy, save money, and improve yields.



60 Risk Index
Powdery Mildew



25.8 °C
Temperature



7

Leaf Wetness

